



 **DE ROSA**

2017  
DEALERS



**DE ROSA**

| **INDICE** | **INDEX** |

SK Pininfarina Luxury .....	2
SK Pininfarina Disk .....	6
SK Pininfarina H2 Speed .....	10
SK Pininfarina .....	14
King XS .....	18
Idol .....	22
Planet .....	26
Nick .....	30
Solo .....	34
Tredecinque .....	38
Nuovo Classico .....	42
Âgè .....	46
Corum .....	50
Scandium .....	54



DE ROSA SK PININFARINA LUXURY

## L'EVOLUZIONE DELLA SPECIE THE EVOLUTION OF A SPECIES

#lusso #tradizione - #luxury #tradition



| CAVIAR BLACK |

La verniciatura mirrow triplo strato, la copertura texture antiscivolo di manubrio e sella, la tecnologia Attrito Zero applicata al cambio, le nuove colorazioni (Nero Caviale, Silver Diamond, Blu Pininfarina), la Sk De Rosa Bike Suitcase e il primo

Body-Bike con un'unica cucitura aggiungono esclusività e unicità alla bici che per definizione è la sintesi perfetta tra stile e alte prestazioni. Un prodotto *haute couture* che racconta tutta la creatività di un progetto *All Made In Italy*.



| SILVER DIAMOND |



| PININFARINA BLUE |

Three layer reflective coating on the paint, the non-slip texture of the handlebars and saddle, the application of Zero Friction technology to the shifters as well as the custom colors – Caviar Black, Silver Diamond, Pininfarina Blue – along

with the SK De Rosa bike suitcase and single needle tailored clothing converge to create the perfect blend of elements that define perfectbody/ bike uniqueness, exclusivity, style, luxury, and of course, performance.

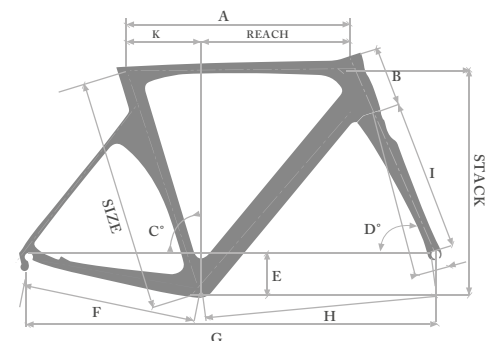

| SPECIFICHE TECNICHE | TECHNICAL SPECIFICATIONS |

SIZE	REACH	STACK	A	B	C*	D*	E	F	G	H	I	J	K	TRAIL
460	369	478	503	82	74°6'	70°7'	70	396	955	569	368	50	122	65
480	374	496	516	100	74°3'	70°9'	70	396	964	579	368	50	130	63.8
500	379	514	528	118	74°0'	71°2'	70	398	975	587	368	50	138	61.9
520	384	532	541	136	73°7'	71°4'	70	398	984	596	368	50	146	60.7
540	389	550	553	148	73°4'	72°7'	70	400	978	588	368	43	154	59.9
560	394	568	567	166	73°1'	72°9'	70	400	986	596	368	43	163	58.7
580	399	586	580	184	72°8'	73°2'	70	402	996	604	368	43	172	56.8
600	404	604	594	202	72°5'	73°4'	70	402	1004	612	368	43	180	55.6

Frame	Fork	Headset Size	Bb Size	Mech/Electronic	Seatpost	Material Composition
990gr	400gr	1 1/8 + 1 1/4	86,5 x 46	Both	Dedicated	Carbon 10,7% 24T+58,1% 30 + 24.3% 40T+6,9% 60 T

| DOTAZIONE | COMPONENTS |

Colore Color	Gruppo Group	Ruote Wheels	Manubrio Handlebar	Reggisella Seatpost	Sella Saddle	Gomme Tires	Pedali Pedals	Portaborraccia Bottlecage
Blu Pininfarina	Campagnolo Super Record Eps	Campagnolo Bora 80	Fsa Plasma Texture	De Rosa	Italia Slr Texture	Vittoria Corsa Speed Graphene	Look Keo Blade 2 Ti	Elite Carbon
Silver Diamond	Campagnolo Super Record Eps	Campagnolo Bora 80	Fsa Plasma Texture	De Rosa	Italia Slr Texture	Vittoria Corsa Speed Graphene	Look Keo Blade 2 Ti	Elite Carbon
Nero Caviale	Campagnolo Super Record Eps	Campagnolo Bora 80	Fsa Plasma Texture	De Rosa	Italia Slr texture	Vittoria Corsa Speed Graphene	Look Keo Blade 2 Ti	Elite Carbon





DE ROSA SK PININFARINA DISK

## GENIO E REGOLATEZZA INGENUITY AND BALANCE

#versatilità #inarrestabile - #versatility #limitless



| BIANCO ARIA |

Il futuro comincia ora. Non conosce limiti, ama rimodellarli e farli propri. L'impianto frenante a disco viene inserito in gamma grazie alla grande versatilità e capacità di interpretare tutte le sfumature dell'anima del ciclista.

De Rosa SK Pininfarina è un progetto ancora tutto da scoprire che alla tecnica aggiunge quel pizzico di sana follia di chi ha scritto e diffuso la cultura e l'amore per la bicicletta, guardando sempre al futuro facendo tesoro del passato.



The future is here and now, embodied in the disc brake version of the SK Pininfarina, a frame that knows no limits and can be customized to become one's own! Adding a disc brake system is just one more way in which DeRosa provides the versatility required for cyclist and bicycle to merge the nuances

of their individual souls. DeRosa SK Pininfarina is a project where technological refinements and distinctions are layered onto the cultural past of cycling to create an irreplaceable experience whose foundation is in the past yet maintains a strong focus on the limitless possibilities of the future.

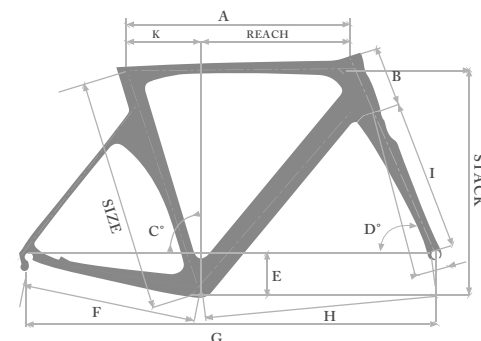

| SPECIFICHE TECNICHE | TECHNICAL SPECIFICATIONS |

SIZE	REACH	STACK	A	B	C°	D°	E	F	G	H	I	J	K	TRAIL
460	369	478	503	82	74°6'	70°7'	70	396	955	569	368	50	122	65
480	374	496	516	100	74°3'	70°9'	70	396	964	579	368	50	130	63.8
500	379	514	528	118	74°0'	71°2'	70	398	975	587	368	50	138	61.9
520	384	532	541	136	73°7'	71°4'	70	398	984	596	368	50	146	60.7
540	389	550	553	148	73°4'	72°7'	70	400	978	588	368	43	154	59.9
560	394	568	567	166	73°1'	72°9'	70	400	986	596	368	43	163	58.7
580	399	586	580	184	72°8'	73°2'	70	402	996	604	368	43	172	56.8
600	404	604	594	202	72°5'	73°4'	70	402	1004	612	368	43	180	55.6

Frame	Fork	Headset Size	Bb Size	Mech/Eletronic	Seatpost	Material Composition
990gr	400gr	1 1/8 + 1 1/4	86,5 x 46	Both	Dedicated	Carbon 10,7% 24T+58,1% 30 + 24.3% 40T+6,9% 60 T

| DOTAZIONE | COMPONENTS |

Colore Color	Gruppo Group	Ruote Wheels	Attacco Stem	Manubrio Handlebar	Reggisella Seatpost	Sella Saddle	Gomme Tires	Pedali Pedals	Portaborraccia Bottlecage
Bianco Aria	Shimano Dura-Ace	Fsa Metron Disk	Fsa Os-99	Fsa K-Force	De Rosa	Italia Slr Carbon	Vittoria Corsa	Look Keo Blade	Elite Carbon



DE ROSA SK PININFARINA H2 SPEED

ACQUA PER VIVERE,  
OSSIGENO PER RESPIRARE  
A DREAM COME TRUE

.....  
#aerodinamica #dreamyourself - #aerodynamic #believeinyourdreams  
.....



| H2 SPEED |

La limited edition H2Speed De Rosa Sk Pininfarina nasce dall'omonimo progetto della quattro ruote. Creata nella fabbrica dei sogni di Cusano Milanino, debutta al Giro d'Italia 2016. Damiano Cunego in sella alla bicicletta con il

telaio bianco, arancione e giallo fluo proprio come l'auto, scatta in volata per inseguire e afferrare il sogno. Il suo sogno. H2Speed De Rosa Sk Pininfarina è la prova che i desideri si avverano.



The limited edition H2Speed De Rosa SK Pininfarina was born from a dream project on four wheels. Our two wheel project was conceived and created in our two wheel dream factory in Cusano Milanino and debuted in the Giro d'Italia 2016. With team Captain Damiano Cunego at its helm, the orange,

white and fluorescent yellow two wheel dream machine rode as if it were shot from a muzzle with rider and bike chasing, and for many stages catching, their dream together. H2Speed De Rosa SK Pininfarina – believe in your dreams!

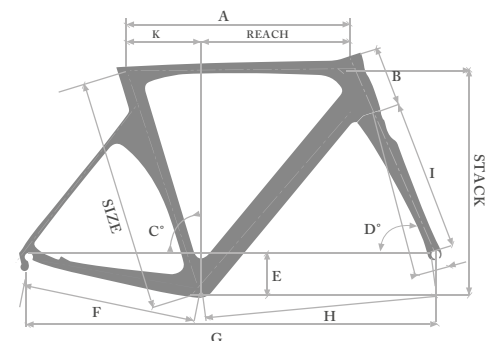

| SPECIFICHE TECNICHE | TECHNICAL SPECIFICATIONS |

SIZE	REACH	STACK	A	B	C°	D°	E	F	G	H	I	J	K	TRAIL
460	369	478	503	82	74°6'	70°7'	70	396	955	569	368	50	122	65
480	374	496	516	100	74°3'	70°9'	70	396	964	579	368	50	130	63.8
500	379	514	528	118	74°0'	71°2'	70	398	975	587	368	50	138	61.9
520	384	532	541	136	73°7'	71°4'	70	398	984	596	368	50	146	60.7
540	389	550	553	148	73°4'	72°7'	70	400	978	588	368	43	154	59.9
560	394	568	567	166	73°1'	72°9'	70	400	986	596	368	43	163	58.7
580	399	586	580	184	72°8'	73°2'	70	402	996	604	368	43	172	56.8
600	404	604	594	202	72°5'	73°4'	70	402	1004	612	368	43	180	55.6

Frame	Fork	Headset Size	Bb Size	Mech/Electronic	Seatpost	Material Composition
990gr	400gr	1 1/8 + 1 1/4	86,5 x 46	Both	Dedicated	Carbon 10,7% 24T+58,1% 30 + 24.3% 40T+6,9% 60 T

| DOTAZIONE | COMPONENTS |

Colore Color	Gruppo Group	Ruote Wheels	Manubrio Handlebar	Reggisella Seatpost	Sella Saddle	Gomme Tires	Pedali Pedals	Portaborraccia Bottlecage
H2 Speed	Campagnolo Super Record Eps	Campagnolo Bora 80	Fsa Plasma Leather	De Rosa	Selle Italia Slr	Vittoria Corsa Speed Graphene	Look Keo Blade 2 Ti	Elite Carbon







DE ROSA SK PININFARINA

# LA TRADIZIONE PER LA BELLEZZA TRADITION BECOMES BEAUTY

*#lusso #tradizione - #luxury #tradition*



| BLU ACQUA |

La sfida conquista. Ma le similitudini uniscono. Come le migliori storie d'amore, De Rosa e Pininfarina si sono incontrate condividendo i valori: la tradizione imprenditoriale familiare, la passione per l'innovazione, la continua ricerca di

alte performance, l'artigianalità e l'attenzione per il dettaglio, l'amore per il design e per la bellezza.

È nata da così la bicicletta che si distingue per le linee eleganti, l'aerodinamicità, la leggerezza e la velocità.



| ROSSO FUOCO |



| NERO TERRA |



| NERO E ROSSO FUOCO |

Challenge conquers. But similarities unite. Like all the best love stories, De Rosa and Pininfarina came together through shared values: born from family craftsmanship, the passion for innovation, the continuous search for high-performance, artisanship

and attention to detail, and an everlasting adoration of design and beauty.

A unison of values that brought to life a lightweight, aerodynamic bicycle with svelte lines and technological perfection.

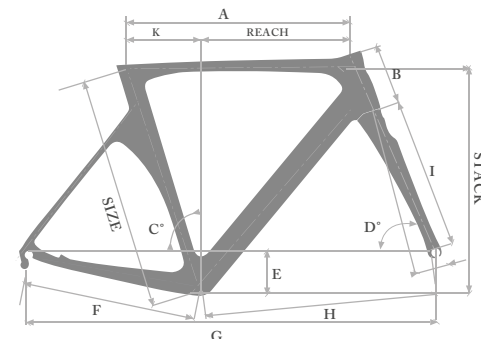

| SPECIFICHE TECNICHE | TECHNICAL SPECIFICATIONS |

SIZE	REACH	STACK	A	B	C°	D°	E	F	G	H	I	J	K	TRAIL
460	369	478	503	82	74°6'	70°7'	70	396	955	569	368	50	122	65
480	374	496	516	100	74°3'	70°9'	70	396	964	579	368	50	130	63.8
500	379	514	528	118	74°0'	71°2'	70	398	975	587	368	50	138	61.9
520	384	532	541	136	73°7'	71°4'	70	398	984	596	368	50	146	60.7
540	389	550	553	148	73°4'	72°7'	70	400	978	588	368	43	154	59.9
560	394	568	567	166	73°1'	72°9'	70	400	986	596	368	43	163	58.7
580	399	586	580	184	72°8'	73°2'	70	402	996	604	368	43	172	56.8
600	404	604	594	202	72°5'	73°4'	70	402	1004	612	368	43	180	55.6

Frame	Fork	Headset Size	Bb Size	Mech/Electronic	Seatpost	Material Composition
990gr	400gr	1 1/8 + 1 1/4	86,5 x 46	Both	Dedicated	Carbon 10,7% 24T+58,1% 30 + 24.3% 40T+6,9% 60 T

| DOTAZIONE | COMPONENTS |

Colore Color	Gruppo Group	Ruote Wheels	Manubrio Handlebar	Reggisella Seatpost	Sella Saddle	Gomme Tires	Pedali Pedals	Portaborraccia Bottlecage
Nero Rosso Fuoco	Campagnolo Super Record Eps	Campagnolo Bora	Fsa Plasma	De Rosa	Italia Slr Carbon	Vittoria Corsa	Look Keo Blade	Elite Carbon
Rosso Fuoco	Campagnolo Super Record Eps	Campagnolo Bora	Fsa Plasma	De Rosa	Italia Slr Carbon	Vittoria Corsa	Look Keo Blade	Elite Carbon
Blu Acqua	Campagnolo Super Record Eps	Campagnolo Bora	Fsa Plasma	De Rosa	Italia Slr Carbon	Vittoria Corsa	Look Keo Blade	Elite Carbon
Nero Terra	Campagnolo Super Record Eps	Campagnolo Bora	Fsa Plasma	De Rosa	Italia Slr Carbon	Vittoria Corsa	Look Keo Blade	Elite Carbon



# KING XS

LA PRIMA NON SI SCORDA MAI  
WE ALWAYS REMEMBER THE FIRST

#contemporanea #confortevole - #contemporary #comfort



| ROSSO FUOCO |



**King XS** è l'up-grade del primo progetto in carbonio di Cusano Milanino che cambia grafiche e si presenta con i nuovi colori Lime e Faema, Grey, Rosso Fuoco, Nero Milano, Bob Black. Pensata e progettata per rispondere alle esigenze

dei granfondisti, è una bici altamente performante che unendo la leggerezza all'agilità si configura come un mezzo confortevole e scattante, allo stesso tempo maneggevole e versatile. Una delle migliori espressioni del carbonio.



| NERO MILANO |



| GREY |



| BOB BLACK |



| FAEMA |



| LIME |

**King XS** evolves from the first-ever carbon project developed by De Rosa in Cusano Milanino and is being presented with completely new graphics and colors: Lime Green, Faema Red, Grey, Fire Engine Red, Matte/Gloss Black and Black. The De Rosa **King XS** was developed specifically

to address the needs of the long distance high performance cyclist (think Gran Fondo), perfectly combining lightweight, agile responsiveness, comfort and performance. It is one of the finest expressions of the use of carbon fiber in bike frame development.

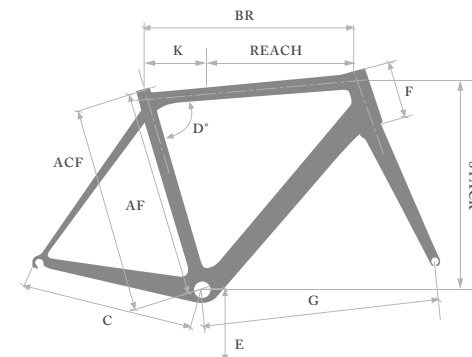

| SPECIFICHE TECNICHE | TECHNICAL SPECIFICATIONS |

ACF cm	BR cm	C cm	D°	E cm	F cm	G cm	REACH	STACK
41.7	50.5	40.5	75°30'	26.8	11	58	37.2	50.1
45	50.7	40.2	75°	26.8	11	57.3	37	50.4
47	51.9	40.2	75°	26.8	11.7	57.6	38	51.5
49	53.4	40.4	74°40'	26.8	12.6	57.9	38.7	52.6
51	54.5	40.5	73°90'	26.5	13.4	58.3	39	53.5
53	55.5	40.77	73°50'	26.5	14.4	58.6	39.3	54.5



Frame	Fork	Headset Size	Bb Size	Mech/Electronic	Seatpost	Material Composition
920gr	400gr	1 1/8 + 1 1/4	86,5 x 46	Both	Dedicated 31,6	CarbonTl1000+Tl1800+XN10

| DOTAZIONE | COMPONENTS |

Colore Color	Gruppo Group	Ruote Wheels	Attacco Stem	Manubrio Handlebar	Reggisella Seatpost	Sella Saddle	Gomme Tires	Pedali Pedals	Portaborraccia Bottlecage
Bob Black	Shimano Dura-Ace 9100	Fsa Metron	Fsa Os-99	Fsa K-Force	De Rosa	Italia Slr Carbon	Vittoria Corsa	Look Keo Blade	Elite Carbon
Faema	Campagnolo Super Record 11V	Campagnolo Bora 50	Fsa Os-99	Fsa K-Force	De Rosa	Italia Slr Carbon	Vittoria Corsa	Look Keo Blade	Elite Carbon
Rosso Fuoco	Campagnolo Chorus Eps	Fsa Metron	Fsa Os-99	Fsa K-Force	De Rosa	Italia Slr Manganese	Vittoria Corsa	Look Keo 2 Max	Elite Carbon
Nero Milano	Campagnolo Potenza 11V	Fsa Metron	Fsa Os-99	Fsa K-Force	De Rosa	Italia Slr Manganese	Vittoria Corsa	Look Keo 2 Max	Elite Carbon
Grey	Campagnolo Chorus 11V	Fsa Metron	Fsa Os-99	Fsa K-Force	De Rosa	Italia Slr Carbon	Vittoria Corsa	Look Keo Blade	Elite Carbon
Lime	Shimano Ultegra 6800	Fsa Metron	Fsa Os-99	Fsa K-Force	De Rosa	Italia Slr Manganese	Vittoria Corsa	Look Keo 2 Max	Elite Carbon



# IDOL

LO STILE DA VENERARE  
STYLE TO REVERE

.....  
#animarock #bella - #rockstar #beauty  
.....



| SILVER MC |



| BLU POTENZA |



| GG |



| WHITE |

.....  
É bella nella sua estetica.

É sacrale nei suoi valori.

É come una star, dall'anima rock.

La **Idol**, con il telaio in carbonio, monta sia i freni a disco sia la soluzione più tradizionale.

Nella sua geometria e nella ricercatezza del suo design si esprimono l'esperienza e la storia De Rosa. Sa di mito ed è per chi vuole ottenere performance eccellenti ed è pronto ad accogliere applausi a scena aperta.

.....  
The **Idol** is perfectly named, designed with beautiful lines and aesthetics that contain the soul of a rockstar!

The carbon frame of the Idol can be mounted with disc or traditional brakes. The geometry and the

design are a clear expression of the capability and intent that underlies each and every De Rosa frame. Just like a rockstar, the Idol is capable of mythical performances that cause its audience to give it a standing ovation and spontaneous applause.

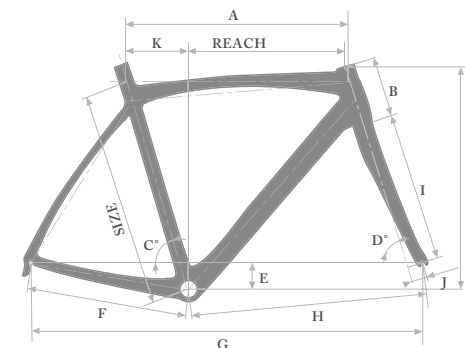

| SPECIFICHE TECNICHE | TECHNICAL SPECIFICATIONS |

SIZE	A cm	B cm	C°	D°	E cm	F cm	G cm	H cm	I cm	K cm	REACH	STACK
47	51.7	11.1	74°20'	71°	7	40.6	97.3	57.8	36.8	12.8	37.0	50.7
49.5	52.9	11.8	73°90'	72°	7	40.8	97.8	58	36.8	13.7	37.8	51.7
52	54.3	13.5	73°60'	72°60'	7	40.8	97.7	58	36.8	14.5	38.4	53.7
54.5	56	15.4	73°	73°	7	41	98.8	58.8	36.8	15.9	39	55.7
57	57.2	17.5	73°	73°10'	7	41	99.9	59.9	36.8	16.5	39.6	57.7
59.5	58.8	19.5	72°70'	73°30'	7	41.2	101.1	60.9	36.8	17.5	40.2	59.7

Frame	Fork	Headset Size	Bb Size	Mech/Electronic	Seatpost	Material Composition
1,250gr	400gr	1 1/8 + 1 1/4	86,5 x 46	Both	31.6	Carbon 70% TI1000+ 30% TI1800

| DOTAZIONE | COMPONENTS |

Colore Color	Gruppo Group	Ruote Wheels	Attacco Stem	Manubrio Handlebar	Reggisella Seatpost	Sella Saddle	Gomme Tires	Pedali Pedals	Portaborracchia Bottlecage
Silver Mc	Shimano Ultegra 6800	Fulcrum Racing Quattro	Fsa Slk	Fsa Energy	Fsa Slk	Selle Italia Slr Manganese	Vittoria Rubino Iv Graphene	Look Keo 2 Max	Elite Carbon
White	Campagnolo Chorus 11V	Campagnolo Shamal Black	Fsa Slk	Fsa Energy	Fsa Slk	Selle Italia Slr Manganese	Vittoria Rubino Iv Graphene	Look Keo 2 Max	Elite Carbon
Blu Potenza	Campagnolo Potenza 11V	Campagnolo Scirocco	Fsa Slk	Fsa Energy	Fsa Slk	Selle Italia Slr	Vittoria Rubino Iv Graphene	Look Keo 2 Max	Elite Carbon
Gg	Shimano Ultegra	Fsa T30 Disk	Fsa Slk	Fsa Energy	Fsa Slk	Selle Italia Slr Manganese	Vittoria Rubino Graphene	Look Keo 2 Max	Elite Carbon



# PLANET

L'EQUILIBRIO PER TUTTI  
PERFECTLY BALANCED FOR EVERYONE

.....  
#libera #accessibile - #balance #accessible  
.....



| ROSSO |

Il telaio in fibra di carbonio attorno al quale scegliere i componenti adatti alle proprie esigenze, per ottenere il prodotto che soddisfa nei contenuti rimanendo accessibile: è questa la **Planet**.

La bicicletta che si presenta con cinque colorazioni e che garantisce la performance. Un successo consolidato, per chi vuole compiere un piccolo passo per pedalare verso ottime prestazioni.



| NEON BLU |



| NERO BIANCO |



| NERO GRIGIO |

The **De Rosa Planet** is the carbon fiber frame that is accessible to every cyclist offering the opportunity to create their perfect bike and be secure in the knowledge that their personal experience the ultimate in performance, comfort and style.

The **Planet** is offered in a variety of frame sizes and five distinct colors; it is a proven success and the perfect choice for someone taking their first few steps into the incredible world of cycling.

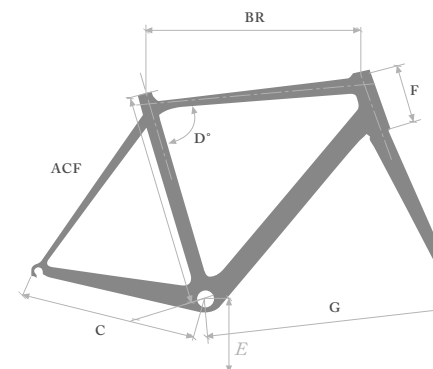

| SPECIFICHE TECNICHE | TECHNICAL SPECIFICATIONS |

ACF <i>cm</i>	BR <i>cm</i>	C <i>cm</i>	D°	E <i>cm</i>	F <i>cm</i>	G <i>cm</i>
47	51.4	40.6	74°50'	26.8	11	57.4
50	52.5	40.6	74°50'	26.8	12.2	57.7
53	53.8	40.6	74°50'	26.5	14.5	58.3
55	55.5	40.6	73°50'	26.5	16	58.9
58	57	40.9	73°	26.5	19.5	59.9

Frame	Fork	Headset Size	Bb Size	Mech/Eletronic	Seatpost	Material Composition
1050gr	400gr	1 1/8 + 1 1/2	68 x 46	Both	31.6	Carbon monoque



| DOTAZIONE | COMPONENTS |

Colore Color	Gruppo Group	Ruote Wheels	Attacco Stem	Manubrio Handlebar	Reggisella Seatpost	Sella Saddle	Gomme Tires	Pedali Pedals	Portaborraccia Bottlecage
Rosso Red	Shimano Ultegra 6800	Fulcrum Racing Quattro	Fsa Os168	Fsa Vero	Fsa Gossamer	Italia Sls	Vittoria Zaffiro	Look Keo Easy De Rosa	Elite Custom Race
Neon Blu	Campagnolo Veloce 10V	Campagnolo Khamxin	Fsa Os168	Fsa Vero	Fsa Gossamer	Italia Sls	Vittoria Zaffiro	Look Keo Easy De Rosa	Elite Custom Race
Nero Bianco Black White	Shmano 105 5800	Fulcrum Racing 7	Fsa Os168	Fsa Vero	Fsa Gossamer	Italia Sls	Vittoria Zaffiro	Look Keo Easy De Rosa	Elite Custom Race
Nero Grigio Dark Grey	Campagnolo Potenza 11V	Campagnolo Scirocco	Fsa Os168	Fsa Vero	Fsa Gossamer	Italia Sls	Vittoria Zaffiro	Look Keo Easy De Rosa	Elite Custom Race





# NICK

LA PRIMA VOLTA  
THE FIRST TIME

.....  
#invitante #fresca - #fresh #myfirstride  
.....



| ARGENTO BLU |



| NERO BLU |



| BIANCO NERO ROSSO |



| NERO VERDE |



| BIANCO GIALLO |

Perfetta per chi sale in sella a una De Rosa per la prima volta. Un vero e proprio concentrato di tecnologia à porter, per un approccio moderno, immediato e bike-friendly. Il tratto graffiante della grafica accompagna le linee pulite di una bicicletta sobria ma di carattere, come il

suo nome. Nick, l'affettuoso nomignolo di Nicholas De Rosa, scritto di getto su un foglio bianco ha conquistato le terre del Sol Levante per la sua freschezza, immediatezza e grande comunicabilità ancor prima di diventare "la prima volta".

The **Nick**, so named using the affectionate name for Nicholas DeRosa, the oldest son in the third generation of De Rosa frame builders, is THE perfect choice of bike for those who ride a DeRosa, or any bike for that matter, for the first time. Nick combines De Rosa technology with a modern look that satisfies both the eye and the rider once he or she mounts the

bike. The graphics are derived from the character of the person after whom the bike is named, as are the clean lines of the frame; character and quiet strength that is understood immediately rather than called to our attention. Nick, with its fresh and welcoming look has humbly conquered the land of the Rising Sun.

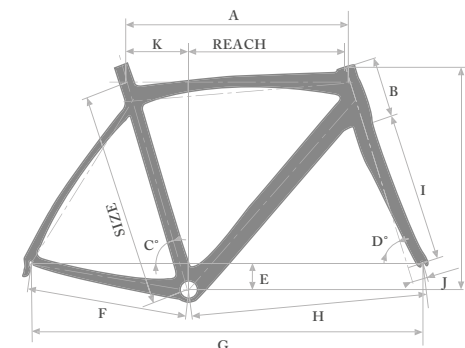

| SPECIFICHE TECNICHE | TECHNICAL SPECIFICATIONS |

SIZE	A cm	B cm	C°	D°	E cm	F cm	G cm	H cm	I cm	K cm	REACH	STACK
47	51.7	11.1	74°20'	71°	7	40.6	97.3	57.8	36.8	12.8	37.0	50.7
49.5	52.9	11.8	73°90'	72°	7	40.8	97.8	58	36.8	13.7	37.8	51.7
52	54.3	13.5	73°60'	72°60'	7	40.8	97.7	58	36.8	14.5	38.4	53.7
54.5	56	15.4	73°	73°	7	41	98.8	58.8	36.8	15.9	39	55.7
57	57.2	17.5	73°	73°10'	7	41	99.9	59.9	36.8	16.5	39.6	57.7
59.5	58.8	19.5	72°70'	73°30'	7	41.2	101.1	60.9	36.8	17.5	40.2	59.7

Frame	Fork	Headset Size	Bb Size	Mech/Electronic	Seatpost	Material Composition
1000gr	400gr	1 1/8 + 1 1/2	85,5 x 46	Both	31.6	Carbon 48,5% 24T+ 51.5% 30T

| DOTAZIONE | COMPONENTS |

Colore Color	Gruppo Group	Ruote Wheels	Attacco Stem	Manubrio Handlebar	Reggisella Seatpost	Sella Saddle	Gomme Tires	Pedali Pedals	Portaborraccia Bottlecage
Bianco Nero Rosso White Black Red	Shimano Ultegra 6800	Fulcrum Racing 5	Fsa Os168	Fsa Vero	Fsa Gossamer	Italia Sls	Vittoria Zaffiro	Look Keo Easy De Rosa	Elite Custom Race
Bianco Gialla White Yellow	Campagnolo Veloce 10V	Campagnolo Khamsin	Fsa Os168	Fsa Vero	Fsa Gossamer	Italia Sls	Vittoria Zaffiro	Look Keo Easy De Rosa	Elite Custom Race
Argento Blu Silver Blue	Shimano Tiagra 4700	Fulcrum Racing 7	Fsa Os168	Fsa Vero	Fsa Gossamer	Italia Sls	Vittoria Zaffiro	Look Keo Easy	Elite Custom Race
Nero Blu Rosso Black Blue Red	Shimano 105 5800	Fulcrum Racing 7	Fsa Os168	Fsa Vero	Fsa Gossamer	Italia Sls	Vittoria Zaffiro	Look Keo Easy De Rosa	Elite Custom Race
Nero Verde Black Green	Shimano 105 5800	Fulcrum Racing 7	Fsa Os168	Fsa Vero	Fsa Gossamer	Italia Sls	Vittoria Zaffiro	Look Keo Easy De Rosa	Elite Custom Race



# Solo ...

SOLO TU, IMMENSO  
THE ONE AND ONLY

#orgoglio #assolo - #pride #oneandonly



| SOLO |

L'assoluto in De Rosa si chiama **Titanio Solo**. Il telaio che, con le sue linee scrive la storia. Tubazioni over size a triplo spessore, trafilate con la massima precisione, in grado 9 come le minuterie.

Solo perché è unico, perché è esclusivo e *taylor made*, perché significa orgoglio, perché è l'opera d'arte che esce da Cusano Milanino. È la promessa d'amore, passione, tecnologia, materia, filosofia e cultura della bicicletta.



The utmost in De Rosa frames is called **Titanio Solo** – the One and Only. The frame, with lines written in history, triple butted oversizing tubing that has been cold drawn with the utmost precision in Grade 9 Titanium. The **Titanio Solo** is unique, special, and made to measure for the discerning cyclist. TitanioSolo

is a work of art made directly by the artisan frame builders in Cusano Milanino; pride describes both their craftsmanship and your ownership. It is the promise of all the feelings and components that are the foundation of the cycling lifestyle: love, joy, passion, technology, unique materials, philosophy and culture.

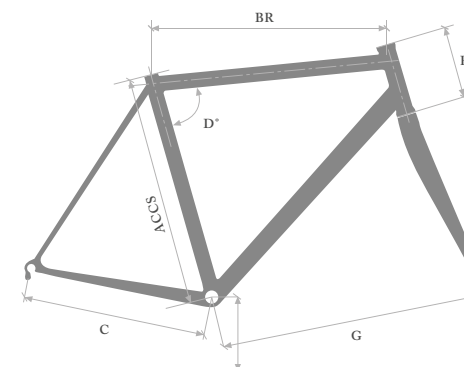
**| SPECIFICHE TECNICHE | TECHNICAL SPECIFICATIONS |**

SLOPE ACCS	ACCR <i>cm</i>	BR <i>cm</i>	C <i>cm</i>	D°	F <i>cm</i>	G <i>cm</i>
44	48	51	39,8	76°	104	58
45	49	52	40.10	75°88'	111	58
45	50	52.5	40.10	75°15'	122	58.1
46	51	53	40.20	75°	130	58.1
47	52	53.5	40.40	74°30'	137	58.2
48	53	54	40.45	74°15'	146	58.3
49	54	54.5	40.55	74°	154	58.4
50	55	55	40.65	73°45'	165	58.6
51	56	56	40.85	73°10'	173	59
52	57	56.5	40.90	73°	181	59.2
53	58	57.5	40.90	73°	192	60.2
54	59	58	41.00	72°45'	202	60.4
55	60	58.5	41.10	72°30'	212	60.6



Frame	Fork	Headset Size	Bb Size	Mech/Electronic	Seatpost	Material Composition
1350gr	400gr	1 1/8 + 1 1/2	Italian	Both on request	31.6	TIG - Titanium 3,2,5 (grade 9) Oversize

**| DOTAZIONE | COMPONENTS |**

Colore Color	Gruppo Group	Ruote Wheels	Attacco Stem	Manubrio Handlebar	Reggisella Seatpost	Sella Saddle	Gomme Tires	Pedali Pedals	Portaborraccia Bottlecage
Solo	Campagnolo Super Record Eps	Campagnolo Bora 50	Fsa Os-99	Fsa K-Force	Titanio	Italia Slr	Vittoria Corsa	Look Keo Blade	Elite Carbon

# TREDUECINQUE

IL RICONOSCIMENTO  
DELLA MATERIA PRIMA  
RECONNECTING WITH ONE  
OF OUR PRIMARY MATERIALS

#unica #eterna - #unique #timeless



| FASCIA BLU |

All'inizio degli anni '90 De Rosa decide di utilizzare il titanio come materia nobile per realizzare il nuovo progetto **Treduecinque**, che consacra la capacità manifatturiera delle officine De Rosa. Un unico modello diventato oggetto di culto che cambia look

nel tempo, ma non la sua unicità che va oltre le mode. La dimostrazione che dedizione, pazienza e tempo posso modellare anche un materiale eccezionalmente resistente rendendo estrema la piacevolezza di pedalata.



During the early 90's De Rosa embarked on what has become a multi-generational voyage with Titanium in order to perfect the frame known as **Treduecinque** by dedicating a significant portion of the research, development and manufacturing capacity facilities at the De Rosa office to this unique

project. **Treduecinque** has developed a cult following despite the changes required by its evolution. The dedication, patience and time required to work with this incredibly strong material also helps us instill the joy and beauty of the ride into every frame we create!

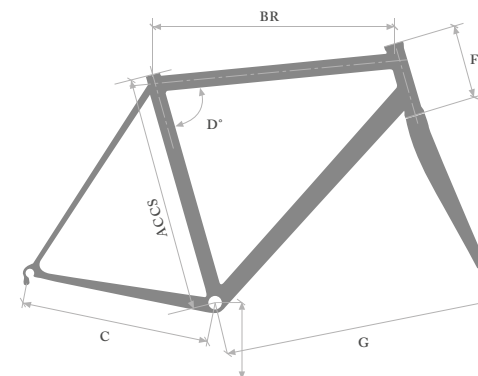

| SPECIFICHE TECNICHE | TECHNICAL SPECIFICATIONS |

SLOPE ACCS	ACCR <i>cm</i>	BR <i>cm</i>	C <i>cm</i>	D°	F <i>cm</i>	G <i>cm</i>
44	48	51	39.80	76°	104	58
45	49	52	40.10	75°88'	111	58
45	50	52.5	40.10	75°15'	122	58.1
46	51	53	40.20	75°	130	58.1
47	52	53.5	40.40	74°30'	137	58.2
48	53	54	40.45	74°15'	146	58.3
49	54	54.5	40.55	74°	154	58.4
50	55	55	40.65	73°45'	165	58.6
51	56	56	40.85	73°10'	173	59
52	57	56.5	40.90	73°	181	59.2
53	58	57.5	40.90	73°	192	60.2
54	59	58	41.00	72°45'	202	60.4
55	60	58.5	41.00	72°30'	212	60.6

Frame	Fork	Headset Size	Bb Size	Mech/Electronic	Seatpost	Material Composition
1300gr	400gr	1 1/8 + 1 1/8	Italian	Both on request	27.2	TIG - Titanium 3,2,5 (grade 9)

| DOTAZIONE | COMPONENTS |

Colore Color	Gruppo Group	Ruote Wheels	Attacco Stem	Manubrio Handlebar	Reggisella Seatpost	Sella Saddle	Gomme Tires	Pedali Pedals	Portaborraccia Bottlecage
Fascia Blu	Campagnolo Chorus Eps	Fsa Metron	Fsa Os-99	Fsa K-Force	Titanio	Italia Slr Carbon	Vittoria Corsa	Look Keo Blade	Elite Carbon



# NUOVO CLASSICO

IL MUST HAVE  
THE MUST HAVE

.....  
#materico #congiunzione - #steel #classic  
.....



| BLU UGO |



| NERO CROMO |



| ROSSO CROMO |

Il lusso della bicicletta su misura, che come l'abito dal taglio sartoriale ha uno stile che fa della distinzione il suo biglietto da visita. L'acciaio è protagonista di un progetto esclusivo che si costruisce intorno a ogni estimatore del dettaglio.

Perché la materia si vede e si sente. Sforare il bordo della congiunzione genera un brivido, che ha il sapore della tradizione, è deciso, forte e determinato. Sono tre i colori, tra i quali l'inconfondibile Blu Ugo, tutti cromo velati.

The change is immediate. The intake of breath and the word "steel", offered with reverence and in hushed tones; that is what happens when a cycling aficionado sees the **Nuovo Classico**. Strength, determination and tradition are the words that describe the Nuovo Classico steel frame, a made to measure for cyclists of discerning taste who appreciate classic styling and

exclusivity. Those who appreciate steel frames move their hand gently over the micro-fuse welded joints and the hand finishes and shudder, simultaneously joyful and incredulous at having found a work of art on two wheels. **Nuovo Classico** is offered in three distinct colors including the unmistakable Ugo Blue.

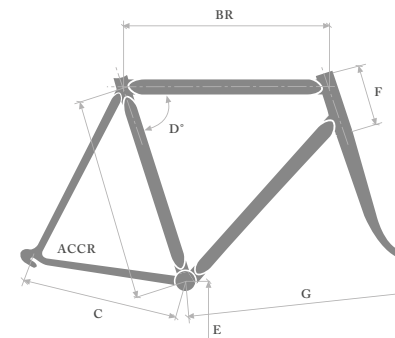
**| SPECIFICHE TECNICHE | TECHNICAL SPECIFICATIONS |**

ACCR cm*	BR cm	C cm	D°	E cm	F cm	G cm
48	52	40	75°30'	26.5	8.2	57.5
49	52	40	75°30'	26.5	9.2	57.5
50	52.5	40	75°15'	26.5	10.2	58
51	53	40	75°	26.5	10.9	58
52	53.5	40.3	74°30'	26.5	11.9	58
53	54	40.5	74°15'	26.5	12.6	58.2
54	54.5	40.7	74°	26.5	13.6	58.4
55	55	40.7	73°50'	26.5	14.4	58.6
56	56	40.8	73°10'	26.5	15.3	59
57	56.5	40.8	73°	26.5	16.3	59.4
58	57.5	40.8	73°	26.5	17.2	59.7
59	58	40.9	72°50'	26.5	18.2	60
60	58.5	41	72°45'	26.5	19.2	60.3
61	59	41.2	72°30'	26.5	20.2	60.8

Frame	Fork	Headset Size	Bb Size	Mech/Eletronic	Seatpost	Material Composition
1850gr	660gr	1" threaded	Italian	Mechanic	27.2	Brazed - Dedacciai 01 steel

**| DOTAZIONE | COMPONENTS |**

Colore Color	Gruppo Group	Ruote Wheels	Attacco Stem	Manubrio Handlebar	Reggisella Seatpost	Sella Saddle	Gomme Tires	Pedali Pedals	Portaborraccia Bottlecage
Rosso Cromo	Campagnolo Chorus 11V	Campagnolo Shamal	Fsa Os168	Fsa Vero	Alloy	Italia Slr Manganese	Vittoria Corsa	Look Keo 2 Max	Elite Carbon
Nero Cromo	Campagnolo Record 11V	Campagnolo Shamal Mille	Fsa Slk	Fsa Slk	Alloy	Italia Slr Manganese	Vittoria Corsa	Look Keo 2 Max	Elite Carbon
Blu Ugo Cromo	Campagnolo Potenza 11V	Fsa Metron	Fsa Os168	Fsa Vero	Alloy	Italia Slr	Vittoria Rubino Pro Iv Graphene	Look Keo 2 Max	Elite Custom Race



# Âgé

D'ACCIAIO SOLO NEL NOME  
A DISTINCTION IN STEEL

#stilysb #senzalimiti - #stylish #limitless



| LUSTER RED |



| ANTRACITE MATTE |



| BLU |

Elegante e raffinata fa centro nel cuore dei ciclisti new-romantic. L'estetica, la tradizione e il gusto per il tratto rétro si antepongono alla prestazione. Âgé è caratterizzata dalla saldatura filled brazed che permette la costruzione di un telaio senza l'utilizzo di congiunzioni.

L'occhio è gratificato dall'armonia di una silhouette omogenea: le sezioni dei tubi nei punti di giunzione sono raccordate in modo uniforme e continuo risultando al tatto un unico corpo. Nessuna barriera, nessun limite di spazio e tempo che vengono enfatizzati dalla nuova gamma colori.

A special style of welding called fillet brazing allows for the creation of a steel frame without showing welded joints. This distinction attracts the romantic cyclist, the cyclist who loves the timelessness of steel frames with sleeker, more modern aesthetics. Like all De Rosa steel frames all that is required is one look and the

cyclist's heart is captured in perpetuity. In that one look the eye is rewarded by the harmony of a homogeneous silhouette. The sections of the tubing at the joints are connected in a uniform and continuous manner resulting in a single body. The new color range offered for the Âgé add to its limitless nature.

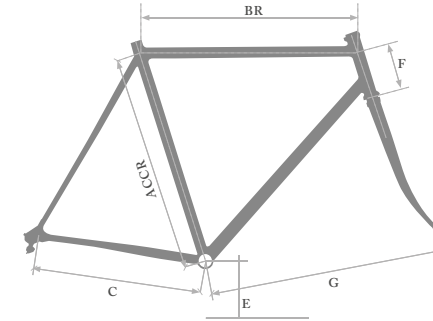

| SPECIFICHE TECNICHE | TECHNICAL SPECIFICATIONS |

ACCR	BR <i>cm</i>	C <i>cm</i>	D°	E <i>cm</i>	F <i>cm</i>	G <i>cm</i>
48	52	40	75°30'	26.7	8.4	57.5
49	52	40	75°30'	26.7	9.2	57.5
50	52.5	40	75°15'	26.7	10.2	57.8
51	53	40	75°	26.7	10.9	58
52	53.5	40.2	74°15'	26.6	11.9	58
53	54.5	40.5	74°15'	26.6	12.6	58.2
54	55	40.7	74°	26.6	13.6	58.4
55	55.5	40.7	73°45'	26.6	14.4	58.6
56	56.5	40.8	73°30'	26.6	15.3	58.8
57	57	40.8	73°15'	26.6	16.3	59.2
58	57.5	40.8	73°	26.6	17.2	59.6
59	58	40.9	73°	26.6	18.2	59.8
60	58.5	41	72°45'	26.6	19.2	60.3
61	59	41.1	72°30'	26.6	20.2	60.8

Frame	Fork	Headset Size	Bb Size	Mech/Eletronic	Seatpost	Material Composition
1850gr	660gr	1" threaded	Italian	Mechanic	27.2	Brazed - Dedacciai 01 steel

| DOTAZIONE | COMPONENTS |

Colore Color	Gruppo Group	Ruote Wheels	Attacco Stem	Manubrio Handlebar	Reggisella Seatpost	Sella Saddle	Gomme Tires	Pedali Pedals	Portaborraccia Bottlecage
Blu	Campagnolo Potenza 11V	Campagnolo Zonda	Deda Elementi	Deda Elementi	Deda Elementi	Italia Slr Manganese	Vittoria Rubino Pro Iv Graphene	Look Keo 2 Max	Elite Carbon
Antracite Matte	Campagnolo Chorus 11V	Campagnolo Shamal Mille	Deda Elementi	Deda Elementi	Deda Elementi	Italia Flite	Vittoria Corsa	Look Keo 2 Max	Elite Carbon
Luster Rosso	Campagnolo Potenza 11V	Fsa Metron	Deda Elementi	Deda Elementi	Deda Elementi	Italia Slr Manganese	Vittoria Corsa	Look Keo 2 Max	Elite Custom Race





# Corum

DOVE OSA LA PERFORMANCE  
IS SHE THE LONE VOICE?

*#visione #speedmaster - #madetomeasure #designedforspeed*



| SILVER REVO |

È lei l'acciaio saldato a Tig, per la coppia che s'incontra alla perfezione. È lei la parte più racing della lega meno morbida. È lei l'eccesso e la tecnologia che si spinge oltre. È lei la visione futura che diventa realtà oggi.

È lei che permette all'acciaio di plasmarsi con misure e dimensioni studiate per chi vuole la velocità costruita in maniera artigianale. È lei la voce fuori dal coro.



| BLU FASCIA GIALLA |



| BIANCO FASCIA BLU |

Is she the steel TIG-weld joint that meets perfectly?  
Is she the racing part of the softer alloy in the fork?  
Is she the technology that goes further?  
Is she tomorrow's vision come true today?

Is it she who allows the steel to merge perfectly with sizes and dimensions designed for those who want speed with a frame built in the traditional way?  
Is she the lone voice?



| SPECIFICHE TECNICHE | TECHNICAL SPECIFICATIONS |

ACCR	BR <i>cm</i>	C <i>cm</i>	D°	E <i>cm</i>	F <i>cm</i>	G <i>cm</i>
48	52	40	75°30'	26.7	8.4	57.5
49	52	40	75°30'	26.7	9.2	57.5
50	52.5	40	75°15'	26.7	10.2	57.8
51	53	40	75°	26.7	10.9	58
52	53.5	40.2	74°15'	26.6	11.9	58
53	54.5	40.5	74°15'	26.6	12.6	58.2
54	55	40.7	74°	26.6	13.6	58.4
55	55.5	40.7	73°45'	26.6	14.4	58.6
56	56.5	40.8	73°30'	26.6	15.3	58.8
57	57	40.8	73°15'	26.6	16.3	59.2
58	57.5	40.8	73°	26.6	17.2	59.6
59	58	40.9	73°	26.6	18.2	59.8
60	58.5	41	72°45'	26.6	19.2	60.3
61	59	41.1	72°30'	26.6	20.2	60.8



Frame	Fork	Headset Size	Bb Size	Mech/Electronic	Seatpost	Material Composition
1660gr	400gr	1 1/8 + 1 1/2	Italian	Both on request	31.6	TIG - Dedacciai steel

| DOTAZIONE | COMPONENTS |

Colore Color	Gruppo Group	Ruote Wheels	Attacco Stem	Manubrio Handlebar	Reggisella Seatpost	Sella Saddle	Gomme Tires	Pedali Pedals	Portaborraccia Bottlecage
Bianco Fascia Blu	Campagnolo Record Eps	Fsa Metron	Fsa Slk	Fsa Slk	Fsa Slk	Italia Slr Manganese	Vittoria Corsa	Look Keo 2 Max	Elite Carbon
Blu Fascia Giallo	Campagnolo Chorus 11V	Fsa Metron	Fsa Slk	Fsa Slk	Fsa Slk	Italia Slr Manganese	Vittoria Corsa	Look Keo 2 Max	Elite Carbon
Revo	Campagnolo Record 11V	Fsa Metron	Fsa Os99	Fsa K-Force	Fsa K-Force	Italia Slr Manganese	Vittoria Corsa	Look Keo 2 Max	Elite Carbon



# SCANDIUM

L'AVANGUARDIA DELLA MODERNITÀ  
THE VANGUARD OF MODERN DESIGN

.....  
#intuizione #avanguardia - #intuitive #vanguard  
.....



| SILVER STUA |



| REFLEX |



| LUSTER RED |

.....  
Alla fine degli anni '90 sul lungomare di Laigueglia, Ugo De Rosa viene colpito dal nuovo trend americano di costruire bici turistiche dal telaio imponente.

L'intuizione è immediata: è necessario aggiornare la tendenza interpretando la cultura italiana votata

alla prestazione. Nasce il telaio in alluminio che poi diventa la **Scandium**, una bicicletta dallo scheletro leggero, che si presenta con le stesse prestazioni del carbonio ma più rigido.

Sempre moderna e attuale è l'avanguardia su due ruote.

.....  
In the late '90s while visiting the Mediterranean coastal town of Laigueglia Ugo De Rosa saw firsthand the new American trend of building tourist bikes using aluminum road bikes frames. Sig. Ugo intuitively realized the need to capitalize on the trend and improve it by infusing it with

Italian design and performance. The aluminum frame was born and grew to become the **Scandium**, a very light frame that matches the performance standards of carbon but is more rigid. **Scandium** is truly the vanguard of modern design and performance in aluminum.

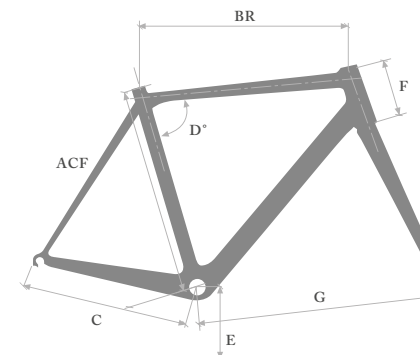
**| SPECIFICHE TECNICHE | TECHNICAL SPECIFICATIONS |**

ACF	BR <i>cm</i>	C <i>cm</i>	D°	E <i>cm</i>	F <i>cm</i>	G <i>cm</i>
45 slope	52	40.5	75°	26.8	12.8	57.5
46.5 slope	53.5	40.5	74°50'	26.8	13.2	57.7
48 slope	54.5	40.7	74°30'	26.8	13.7	58.1
49 slope	55.5	40.7	74°	26.8	14.5	58.6
52 slope	56.5	41	73°	26.8	16.5	59
54 slope	57.5	41	73°	26.8	18.4	59.5
58 regolare	58.5	41.2	72°50'	26.8	18.4	60
60 regolare	60	41.2	72°50'	26.8	20.5	61

Frame	Fork	Headset Size	Bb Size	Mech/Elettronic	Seatpost	Material Composition
1,280gr	400gr	1 1/8 + 1 1/2	86,5 x 41	Both on request	31.6	TIG - Aluminium + Scandium

**| DOTAZIONE | COMPONENTS |**

Colore Color	Gruppo Group	Ruote Wheels	Attacco Stem	Manubrio Handlebar	Reggisella Seatpost	Sella Saddle	Gomme Tires	Pedali Pedals	Portaborraccia Bottlecage
Reflex	Campagnolo Chorus 11V	Fsa Metron	Fsa Os-99	Fsa K-Force	Fsa K-Force	Italia Slr Manganese	Vittoria Corsa	Look Keo 2 Max	Elite Carbon
Silver Stua	Campagnolo Chorus 11V	Fsa Metron	Fsa Os-99	Fsa K-Force	Fsa K-Force	Italia Slr Manganese	Vittoria Corsa	Look Keo 2 Max	Elite Carbon
Rosso Fuoco	Campagnolo Chorus 11V	Fsa Metron	Fsa Os-99	Fsa K-Force	Fsa K-Force	Italia Slr Manganese	Vittoria Corsa	Look Keo 2 Max	Elite Carbon

L'IDEA - THE IDEA

## UN SOGNO SU MISURA A TAILOR MADE DREAM

Cristiano De Rosa



Per raccontarvi il progetto Black Label, voglio fare una premessa.

La nostra azienda è italiana. Ed essere italiani è un privilegio, ma anche una responsabilità.

Vi starete domandando cosa significa questa affermazione.

Semplice: dire sono italiano e produco prodotti italiani vuol dire garantire al cliente e all'intero mercato eleganza, qualità, unicità. Tutte caratteristiche coordinate da un processo creativo completo: dall'idea, al bozzetto, alla realizzazione, al packaging finale con il quale si offre la singola unità.

La cura del dettaglio, l'estro nel design, il connubio tra forma e funzione reso possibile dalla tecnologia applicata per il miglior risultato possibile rendono un prodotto italiano unico. Se migliore, lo diranno i volumi. Ma sulla diversità non ci sono dubbi.

Questo discorso è valido nella moda, nella cucina, nell'arredamento, nelle motociclette, nelle biciclette e maggiormente nel lusso, dunque nell'alto di gamma, di ciascuna categoria.

Dire *made in Italy* è essere consapevoli che si sta generando un'aspettativa molto alta nei termini che ho sopra descritto. Un'aspettativa che vuole essere ripagata, che necessita di certezze e garanzie.

È per questo che quando realizziamo le nostre biciclette rispettiamo tutti questi parametri: perché la nostra realtà è italiana e vogliamo essere ambasciatori di eccellenza.

Ma andiamo oltre e accanto all'eccellenza, come vi accennavo, vogliamo offrire unicità.

Come nella migliore delle tradizioni sartoriali italiane, che confezionano abiti su misura per ogni singola persona, così De Rosa confeziona la bicicletta giusta per la persona giusta.

In order for me to properly speak with you about De Rosa Black Label it is important for me to provide you with what I believe is important information.

Our company is Italian and for us being Italian is a privilege; with privilege comes great responsibility. Perhaps you are wondering what this means; after all, I am about to discuss our bicycles.

For us it is simply this: to say the words "I am Italian and produce Italian products" means ensuring the market in general and each and every customer a unique product of great elegance, quality, and style. Each distinct feature is perfectly combined with every other feature throughout the entire creative process - new idea and continuing on to sketch, technical design, manufacturing, final product, packaging and, where applicable, accessories - culminating in a single coordinated product.

The merging of strict attention to detail, bold and creative design, the marriage of form and function made possible by carefully researched technology applied to achieve the best possible result are the foundational principles in the creation of a unique Italian product. The quality of the products speak for themselves; differentiation is absolutely clear. This discourse and these principles are true in fashion, food, furnishings, motorcycles, and bicycles; exponentially so in the luxury class of each category.

I believe I have expressed my sense of responsibility as it relates to the use of the words "Made in Italy", and that responsibility is this: to be aware that one is creating a very high expectation in the minds and hearts of the customer and that we must reward and guarantee that expectation with certainty.

We carry this responsibility in our hearts when we make our bikes. Our reality is clearly Italian and we want to be ambassadors of excellence.

However, offering excellence is not enough for us, as I mentioned earlier we also want to offer uniqueness.

As is true in the best traditions of Italian tailors who make bespoke suits for every single person, at De Rosa we create the perfect bike for each person. Our customer is able to realize his or her desire to have a work of art tailor made to their exact specifications with great attention to each detail. Beginning with the material and a completely custom frame to choosing an exact color and finish, specific components and accessories; with our

Realizza il desiderio di avere un'opera d'arte tailor made, con l'attenzione per ogni singolo dettaglio: dalla scelta del materiale, al telaio su misura, alla colorazione, fino alla scelta dei componenti e alla finitura richiesta dal cliente.

Questo progetto si chiama **Black Label** e sotto questa "etichetta" rientrano tutti quei prodotti customizzabili, nei quattro materiali che caratterizzano la nostra storia: acciaio, alluminio, titanio, carbonio.

Black Label è l'idea che ha celebrato i primi 60 anni della nostra azienda. Ed è l'iniziativa che ci ha permesso di sottolineare la nostra artigianalità e la nostra capacità di lavorare 4 elementi molto particolari e con caratteristiche differenti, adatte a differenti tipologie di persone.

ACCIAIO  
LA LEGA  
DELLA TENACIA

ALLUMINIO  
LA LEGGEREZZA  
DELL'INTUIZIONE

TITANIO  
LA NOBILTÀ  
DELLA RESISTENZA

CARBONIO  
IL CARATTERE  
DA DOMARE

Vogliamo essere certi di poter realizzare il desiderio di chiunque voglia distinguersi e raccontare parte della propria personalità anche attraverso una bicicletta studiata e realizzata appositamente.

I nostri "maestri" si dedicano a ciascun progetto con la massima attenzione possibile e la concentrazione che l'unicità merita.

In tutto il mondo non ci sarà mai una bicicletta Black Label uguale ad un'altra, sia esteticamente sia dal punto di vista della performance e delle caratteristiche tecniche, perché ogni Black Label è assolutamente irripetibile.

input and support the customer realizes their dream of owning their perfect bike made specifically for them.

This project is called "Black Label".

Under this label we provide all customizable products beginning with the material; Black Label bikes are available in any of the four materials that have defined our history of innovation: steel, aluminum, titanium, and carbon.

Black Label is the idea that celebrated and honored the first 60 years of our company and the initiative that provided us with a platform to highlight our craftsmanship and ability to work with four very distinct elements and materials, each of which is particularly suited for different people.

STEEL

THE LEGACY  
OF TENACITY

ALUMINUM

INNOVATION FOLLOWS  
INTUITION

TITANIUM

A TRADITION  
OF SUPERIORITY

CARBON

BALANCE CREATES  
PERFECTION

Our goal is to be able to fulfill the desire and dream of any customer who, through the bike that was built specifically for him or her, wants to stand out from the crowd, express their unique personality and divulge the innermost workings of their heart and soul.

Our artisans (mechanics, frame builders, painters, designers, support team) dedicate themselves to each project with the greatest possible attention and concentration to each detail; it is what the uniqueness of each project deserves.

Scour the world and you will never find two people who are exactly alike; this is also true of a Black Label bike. Aesthetically, in performance and in technical specifications each bike has its suichness.







 **DE ROSA**

De Rosa Ugo & Figli Srl

Via Bellini n.24, 20095 Cusano Milanino, Milano - Italy

TEL +39 02 61 95 171 - FAX +39 02 61 95 188

[www.derosanews.com](http://www.derosanews.com)