



 **DE ROSA**

collezione 2015



L'evoluzione nasce sulla strada,  
le novità sono nella mente  
di chi corre, nelle sensazioni  
e nei desideri di chi la bicicletta  
la vive dalla sella.

# Questo rende indimenticabile ogni bicicletta De Rosa.

Evolution comes from the road, innovation is inside our mind,  
soul of bikers, inside feelings and desires of who lives biking  
from the saddle.

This makes unforgettable every De Rosa bicycle.



Con questa nuova collezione 2015 De Rosa coniuga tradizione e innovazione, passione e ricerca, storia e futuro. Acciaio, Titanio, Alluminio e Carbonio nuovamente assieme per dare a tutti la possibilità di misurarsi con la propria passione. Modelli storici aggiornati alle ultime tendenze e perfezionati nei particolari per spingere le prestazioni oltre i propri limiti. Nuovi modelli pensati e realizzati per adottare soluzioni di avanguardia. Facciamo questo mestiere da 60 anni e conosciamo la tradizione ciclistica italiana come pochi. Pedalare una De Rosa non sarà mai un'esperienza come le altre.

With this new 2015 collection, De Rosa brings together tradition and innovation, passion and research and history and the future. Steel, titanium, aluminium and carbon come together again to give everybody the possibility of measuring themselves against their own passion. Historical models perfect in every detail to push performance past your own limits. New models designed and manufactured to adapt avant-garde solutions. We have been in this business for 60 years and we know the Italian cycling tradition like no one else. Riding a De Rosa bike is like riding no other bike.

INDEX

**BLACK LABEL**  
pg. 9

**PROTOS**  
pg. 15

**KING XS**  
pg. 23

**888 SUPERKING**  
pg. 33

**IDOL**  
pg. 39

**PLANET**  
pg. 45

**R838**  
pg. 51

**FORMULA KING**  
pg. 57

**TITANIO SOLO**  
pg. 61

**TITANIO 3/2.5**  
pg. 65

**SCATTOFISSO 737**  
pg. 69

**CORUM**  
pg. 71

**NUOVO CLASSICO**  
pg. 75

**NEO PRIMATO**  
pg. 79

**SCANDIUM**  
pg. 83

**TEAM**  
pg. 87

**CLOTHING**  
pg. 91







“Può succedere che i ricordi di sessant’anni possano soppiantare il presente ma

# ciò che faremo è molto di più di ciò che ho fatto:

credo che ancora oggi la bicicletta possa essere migliorata...  
c’è ancora tanto futuro da creare”.

“It is possible that the present can be replaced  
by the memories of 60 years ago but what we will do is more  
than what I have done:  
I believe that nowadays the bicycle can be improved again  
...there is still so much future to create.”





ABBIAMO LA TESTA  
DI UN SARTO E LE MANI  
DI UN MECCANICO

# Solo su misura

We have the head of a tailor  
and the hands of a mechanical  
Only custom made





#### STEEL

Per gli appassionati di questo nobile materiale, la bici è composta solo da acciaio, un materiale resistente. De Rosa vanta 60 anni di storia nella lavorazione dell'acciaio. Conosciamo tutte le sue virtù e sappiamo come trarre vantaggio da esso. Per questa ragione, anche dopo 60 anni, ogni telaio in acciaio è come il nostro primo telaio.

For enthusiasts of this noble material, the bike is made only from steel. A resistant material. De Rosa has 60 years of history in the processing of steel. We know all its virtues and know how to get the best out of it. For this reason, even after 60 years, each steel frame is like it is the first frame for us.



#### TITANIUM

Il materiale (per eccellenza). Punto. La lavorazione del titanio richiede una conoscenza e un'abilità specializzata. Questa competenza che De Rosa ha sviluppato da quasi 20 anni rende ogni telaio un'opera d'arte che combina estetica con performance.

The material. Full stop. To work titanium requires specialist knowledge and skill. This knowledge and skill that De Rosa has developed in almost 20 years makes each frame an aesthetic and performance work of art.



#### ALUMINIUM

Varie sono le leghe di alluminio impiegate e De Rosa utilizza solo le migliori. L'alluminio rappresenta un punto di svolta nella produzione del telaio, fornendo la possibilità di sviluppare nuovi concepts/idee di telai, grazie alla duttilità, leggerezza e resistenza di questo materiale. Per questo continuiamo a credere nell'alluminio.

There are many aluminium alloys that are utilized and in De Rosa we use only the best. Aluminium represents a turning point in frame manufacturing, giving the possibility of developing new frame concepts, thanks to its ductility, lightness and resistance. We still believe in aluminium.



#### CARBON

Il materiale di riferimento per tutti i telai attuali. Rigido, leggero, resistente, reattivo e confortevole. La fibra in carbonio è senza dubbio il presente ed il futuro della bici. De Rosa propone un mix di carbonio high modul e fibre trattate a mano nel nostro workshop a Cusano.

The reference material for all current frames. Rigid, light, resistant, reactive and comfortable. Carbon fibre is without doubt the present and the future of cycling. De Rosa proposes a blend of hi-modul carbon, the fibres of which are hand-layered in our workshop in Cusano.



# De Rosa produce.

Non fa produrre.

Il concetto Su Misura entra a forza nel mondo delle bici. L'arte del sarto viene applicata ai telai da strada. Nessuno lo fa in tutti e quattro i materiali e nessuno lo fa in Italia. Questa è la filosofia Black Label.

De Rosa produces itself, doesn't make someone else produce. The concept of Made to Measure enters forcefully into the world of the very special bikes. The tailor's art is applied to road frames. Nobody does it in all four materials and Nobody does it in all four material in Italy. This is the Black Label philosophy.





# Officina De Rosa Laboratorio di idee

Il legame tra sviluppo scientifico e sviluppo tecnologico è un processo recente a livello storico ma da sempre si realizza nei reparti di produzione dell'azienda De Rosa. "Officina De Rosa" è il risultato di una semplice vestizione: abbiamo solo dato "un abito" alle nostre ricerche e agli sviluppi che poi tutti ritrovano nei nostri telai.

The link between scientific and technological development is a recent process in history but since always takes place in the production of De Rosa. "Officina De Rosa" is the result of a simple dressing: we have only given a gown to our research and all the developments that are in our frames.



# Protos

Protos è il progetto più ambizioso ed innovativo mai realizzato dalla famiglia De Rosa.

Protos is the most ambitious and innovative project ever played by the De Rosa family.

È il risultato di anni di lavoro, ricerca e progettazione: un progetto importante che ha voluto fondere tutto il prezioso "Know How" accumulato in 60 anni di lavoro, con l'ingegneria e il design. Un telaio innovativo, performante, stabile e di grande impatto estetico. Qualcosa senza pari! La capacità di assorbire e disperdere le irregolarità del terreno è ottenuta grazie al particolare design della forcella "Head Flat Face", la quale può vantare un CX invidiabile, addirittura per una bicicletta da cronometro. Protos non lascia nulla al caso. Il material di base è un mix sapiente di 3 fibre di carbonio, applicate e dosate per ottenere un risultato unico. La composizione è formata dal 50% da fibra T1800, il 40% TI 1000, e il 10% da XN60. PROTOS incrementa del 35% il valore STW (stiffness to weight) rispetto alle tradizionali bici da competizione. Il sistema innovativo di cablaggio interno, la soluzione "full integrated", la scatola movimento da 86,5 mm e lo sterzo differenziato da 1 1/8" e 1 1/4", rendono ancora più unico questo telaio. Disponibile in otto misurazioni, anche su misura a richiesta.

The result of years of work, research and engineering: an important project that wanted to merge everything valuable "know how" accumulated in 60 years of work, combined with engineering design. An innovative chassis, high performing, stable and of great aesthetic impact, something unparalleled! The ability to absorb and disperse the irregularities of the terrain have been obtained from the particular design of the fork "Head Flat Face", which can CX boast enviable even for a bicycle time trial. Protos leaves nothing to chance. The material is an expert blend of 3 fibers employed and carefully measured to obtain a precise goal. The composition is made up of 50% T1 800 fiber, 40% TI 1000, and 10% XN60. The PROTOS frame increases the STW (stiffness to weight) value by 35% compared to traditional competition racing bikes. The innovative cabling system inside, the solution "full integrated". The bottom bracket by 86,5 mm and the steering differentiated by 1 1/8" and 1 1/4". Available in eight measurements, also customizable on request.

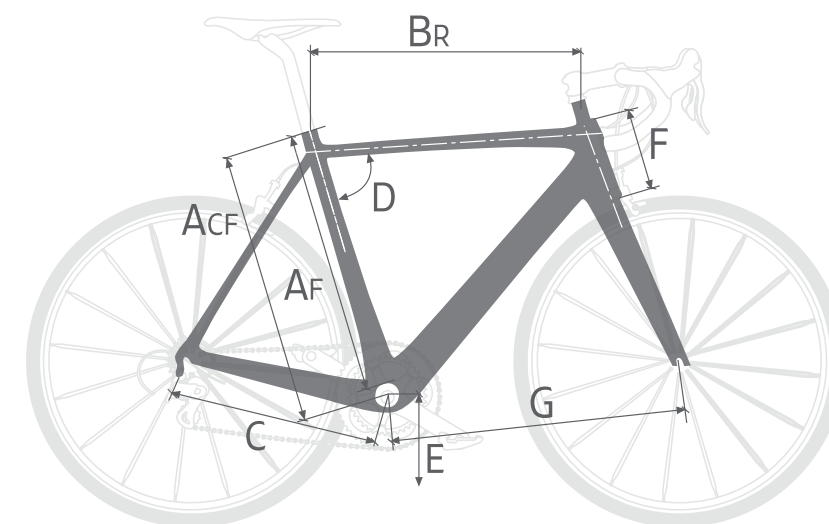

ACFcm**	AFcm*	BRcm	Ccm	D°	Ecm	Fcm	Gcm
47,10	44,5	50,77	40,20	75°	26,70	11	57,30
50,10	47,5	51,98	40,20	75°	26,70	11,72	57,61
52,10	49,5	53,49	40,40	74°40'	26,70	12,62	57,99
54,10	51,5	54,49	40,56	73°90'	26,70	13,47	58,34
55,10	52,5	55,45	40,70	73°50'	26,70	14,40	58,64
57,10	54,5	56,50	40,90	73°	26,70	15,60	59,10
59,10	56,5	57,50	41,10	72°60'	26,70	17	59,70
61,10	58,5	58,93	41,10	72°60'	26,70	19	61

\*Misura AF: sopra scatola movimento/fine tubo sella  
\*Measurement AF: above pedal-gear mechanism/end of saddle tube  
\*\*Misura ACF: centro/fine tubo sella  
\*Measurement ACF: centre/end of saddle tube  
Anche su misura. Also custom size.





# Protos



telaio/frame: **PROTOS**  
gruppo/group: **CAMPAGNOLO SUPER RECORD EPS**  
reggisella/seatpost: **FSA K-FORCE**  
pedali/pedals: **LOOK BLADE**  
curva/handlebar: **FSA K-FORCE CT**  
attacco/stem: **FSA OS99**  
ruote/wheels: **CAMPAGNOLO BORA**  
gomme/tires: **VITTORIA OPEN CX**  
portaborraccia/bottlecage: **CARBON DE ROSA**  
sella/saddle: **SELLE ITALIA SLR**  
colore/color: **NERO LUCIDO / BLACK GLOSS**







DE ROSA  
PROTOS



## Protos Carbon

telaio/frame: PROTOS  
gruppo/group: CAMPAGNOLO RECORD  
reggisella/seatpost: FSA K-FORCE  
pedali/pedals: LOOK 2 MAX  
curva/handlebar: FSA K-FORCE CT  
attacco/stem: FSA OS99  
ruote/wheels: CAMPAGNOLO BORA  
gomme/tires: VITTORIA OPEN CX  
portaborraccia/bottlecage: CARBON DE ROSA  
sella/saddle: SELLE ITALIA SLR  
colore/color: VERDE / BLACK GREEN



## Protos Carbon

telaio/frame: PROTOS  
gruppo/group: CAMPAGNOLO SUPER RECORD  
reggisella/seatpost: FSA K-FORCE  
pedali/pedals: LOOK BLADE  
curva/handlebar: FSA K-FORCE CT  
attacco/stem: FSA OS99  
ruote/wheels: CAMPAGNOLO BORA 50  
gomme/tires: VITTORIA OPEN CX  
portaborraccia/bottlecage: CARBON DE ROSA  
sella/saddle: SELLE ITALIA SLR  
colore/color: ROSSO / BLACK RED





## Protos Carbon

telaio/frame: PROTOS  
 gruppo/group: SHIMANO DURA-ACE DI2  
 reggisella/seatpost: FSA K-FORCE  
 pedali/pedals: LOOK BLADE  
 curva/handlebar: FSA K-FORCE CT  
 attacco/stem: FSA OS99  
 ruote/wheels: FSA METRON DE ROSA  
 gomme/tires: VITTORIA OPEN CX  
 portaborraccia/bottlecage: CARBON DE ROSA  
 sella/saddle: SELLE ITALIA SLR  
 colore/color: BIANCO / BIANCO



## Protos Carbon

telaio/frame: PROTOS  
 gruppo/group: CAMPAGNOLO RECORD  
 reggisella/seatpost: FSA K-FORCE  
 pedali/pedals: LOOK 2 MAX  
 curva/handlebar: FSA K-FORCE CT  
 attacco/stem: FSA OS99  
 ruote/wheels: CAMPAGNOLO BORA  
 gomme/tires: VITTORIA OPEN CX  
 portaborraccia/bottlecage: CARBON DE ROSA  
 sella/saddle: SELLE ITALIA SLR  
 colore/color: NIPPO / BLUE YELLOW

# King XS



La dinastia King continua e si evolve. L'ultimo capostipite si chiama King XS, non si tratta di un restyling, ma bensì di un nuovo progetto per un nuovo telaio. Alleggerito rispetto al precedente modello, King XS adotta nuove soluzioni tecnico/stilistiche. La scelta tecnica più evidente è la scomparsa del freno posteriore dalla sua tradizionale posizione: lo abbiamo posizionato sotto la scatola del movimento centrale. Il freno posteriore così collocato consente un incremento nella potenza di frenata e ci permette di eliminare il classico ponticello freno nel carro posteriore. Tutto questo consente di migliorare il comfort senza compromettere la performance e conferisce al design del telaio una pulizia di linee senza pari. King XS è caratterizzato da una "purezza" di linee che apporta al telaio un'eleganza volutamente "minimale". La geometria del triangolo anteriore si differenzia dall'usuale per l'avvicinamento del tubo obliquo alla ruota anteriore: questo permette di aumentare l'assorbimento delle vibrazioni, senza pregiudicare reattività e stabilità, offrendo al contempo un aspetto più "racing" al prodotto. La forcella si integra allo sterzo ed al telaio in modo poco invasivo, per dare un impatto estetico ed una aerodinamicità elevata. Il materiale utilizzato è quanto di meglio la ricerca nei materiali compositi oggi possa offrire: la sua composizione prevede un blend di 3 materiali, T11000, T1 800 e XN10. King XS è offerto in 8 taglie con geometria semi slope.

The King dynasty continues and evolves. The last forefather is King XS, is not about a restyling, although it is about a new project for a new frame. More lightened than the previous sample, King XS opts for new technical/stylistic solutions. The most evident choice is the disappearance of the rear brake from its traditional position: we have placed it under the bottom bracket. This new position of the rear brake allows an increase of the braking power and permits to remove the traditional brake arch in the rear stays. In this way it is possible to improve the comfort without compromising the performance and it lends the design of the frame a cleaning of lines never seen before. King XS is characterized by a "purity" of lines that gives intentionally to the frame a "minimal" elegance. The structure of the rear triangle is different from the traditional one because of the short distance between the down tube and the front wheel: this system allows to increase the assimilation of vibrations, without compromising reactivity and stability, offering at the same time more "racing" to the product. The fork is integrated with the steering tube and the frame in a not so invasive way in order to give an esthetic impact and high aerodynamic features. The chosen material is the best choice given by the research of composite materials: it is composed by a blend of 3 materials, T11000, T1 800 and XN10. You can choose between 8 sizes of King XS with semi slope structure.

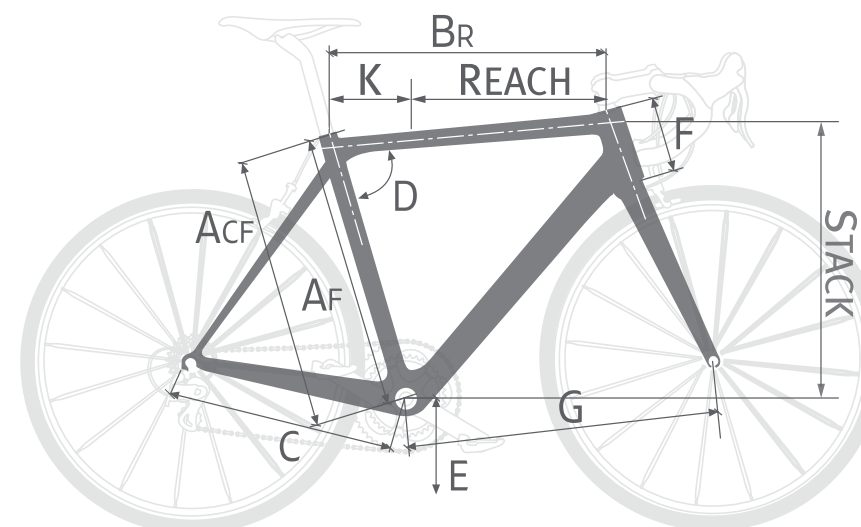

ACF	BR	C	D°	E	F	G	Reach	Stack
41,7	50,5	40,5	75°30'	26,7	11	58	37,2	50,1
49,2	50,7	40,2	75°	26,7	11	57,3	37	50,4
50,3	51,9	40,2	75°	26,7	11,7	57,6	38	51,5
51,6	53,4	40,4	74°40'	26,7	12,6	57,9	38,7	52,6
52,6	54,5	40,5	73°90'	26,7	13,4	58,3	39	53,5
53,8	55,5	40,7	73°50'	26,7	14,4	58,6	39,3	54,5
55,2	56,5	40,9	73°	26,7	15,6	59,1	39,5	55,7
56,7	57,5	41	72°60'	26,7	17	59,7	39,7	57
58,8	58,9	41	72°60'	26,7	19	60,9	40,5	59



# King XS



telaio/frame: **KING XS**  
gruppo/group: **CAMPAGNOLO CHORUS EPS**  
reggisella/seatpost: **FSA K-FORCE**  
pedali/pedals: **LOOK 2 MAX**  
curva/handlebar: **FSA ENERGY CT**  
attacco/stem: **FSA SL-K**  
ruote/wheels: **FSA METRON DE ROSA**  
gomme/tires: **VITTORA OPEN CX**  
portaborraccia/bottlecage: **CARBON DE ROSA**  
sella/saddle: **SELLE ITALIA FLITE**  
colore/color: **GRIGIO / SILVER F1**







## King XS Carbon

telaio/frame: KING XS  
 gruppo/group: CAMPAGNOLO RECORD  
 reggisella/seatpost: FSA K-FORCE  
 pedali/pedals: LOOK 2 MAX  
 curva/handlebar: FSA ENERGY CT  
 attacco/stem: FSA SL-K  
 ruote/wheels: CAMPAGNOLO SHAMAL MILLE  
 gomme/tires: VITTORA OPEN CX  
 portaborraccia/bottlecage: CARBON DE ROSA  
 sella/saddle: SELLE ITALIA SLR  
 colore/color: NERO BLU / BLACK BLUE



## King XS Carbon

telaio/frame: KING XS  
 gruppo/group: CAMPAGNOLO RECORD  
 reggisella/seatpost: FSA K-FORCE  
 pedali/pedals: LOOK 2 MAX  
 curva/handlebar: FSA ENERGY CT  
 attacco/stem: FSA SL-K  
 ruote/wheels: FSA VISION DE ROSA  
 gomme/tires: VITTORA OPEN CX  
 portaborraccia/bottlecage: CARBON DE ROSA  
 sella/saddle: SELLE ITALIA SLR  
 colore/color: NERO LUCIDO / NERO LUCIDO





## King XS Carbon

telaio/frame: KING XS  
gruppo/group: CAMPAGNOLO CHORUS EPS  
reggisella/seatpost: FSA K-FORCE  
pedali/pedals: LOOK 2 MAX  
curva/handlebar: FSA ENERGY CT  
attacco/stem: FSA SL-K  
ruote/wheels: CAMPAGNOLO BULLET  
gomme/tires: VITTORA OPEN CX  
portaborraccia/bottlecage: CARBON DE ROSA  
sella/saddle: SELLE ITALIA SLR  
colore/color: CICLAMINO / CICLAMINO



## King XS Carbon

telaio/frame: KING XS  
gruppo/group: CAMPAGNOLO SUPER RECORD  
reggisella/seatpost: FSA K-FORCE  
pedali/pedals: LOOK BLADE  
curva/handlebar: FSA K-FORCE CT  
attacco/stem: FSA OS99  
ruote/wheels: CAMPAGNOLO BORA  
gomme/tires: VITTORA OPEN CX  
portaborraccia/bottlecage: CARBON DE ROSA  
sella/saddle: SELLE ITALIA SLR  
colore/color: ARANCIO FLUO / FLUO





## King XS

Carbon

telaio/frame: KING XS  
gruppo/group: SHIMANO DURA-ACE  
reggisella/seatpost: FSA K-FORCE  
pedali/pedals: LOOK BLADE  
curva/handlebar: FSA K-FORCE CT  
attacco/stem: FSA OS99  
ruote/wheels: FSA METRON DE ROSA  
gomme/tires: VITTORA OPEN CX  
portaborraccia/bottlecage: CARBON DE ROSA  
sella/saddle: SELLE ITALIA SLR  
colore/color: BIANCO / WHITE

# 888 Superking



Il top di gamma di De Rosa si completa con la serie di telai: "888 Superking", nei modelli "R", "SR", e "E". Il modello "E" è stato progettato per dedicarlo esclusivamente al montaggio dei gruppi elettronici. I modelli "R" e "SR" sono invece dedicati a tutti coloro che sceglieranno i gruppi di montaggio meccanici. La serie 888 Superking è caratterizzata da un "blend" di 3 differenti tipi di fibre composite MR-60 (295 GPA/5800MPa), HR-40 (390GPA/4610MPa) e NGF's 630GPA. Inoltre sono stati aggiunti dei rinforzi strutturali nei punti di maggior sollecitazione usando un "complex" di fibre ad altissimo modulo. La struttura del telaio è sicuramente ricercata ed avanzata, pensata per fornire un basso peso complessivo, elevata rigidità, ma con un migliore assorbimento alle vibrazioni. La serie 888 Superking è caratterizzata da questo componente di smorzamento di vibrazione, unico ed armonico distribuito uniformemente sulla struttura dei posteriori, tubo sella e forcella. Proposta con geometria regolare e in 8 taglie.

The top of the De Rosa range is made complete with the series of frames: 888 Superking in the "R", "SR" and "E" models. The "E" model was designed to be exclusively. Dedicated for the mounting of electronic units. It is a project in synergy with Campagnolo engineers. This model features the possibility of recharging the battery via a plug positioned underneath the water bottle holder. The "R" and "SR" models are instead dedicated to those who choose mechanical mounting units. The series 888 superking is characterized by a "blend" of 3 different types of composite fibers MR-60 (295 GPA/5800MPa), HR-40 (390GPA/4610MPa) and NGF's 630GPA. Addition of structural reinforcements were added at the points of greatest stress using a "complex" of high modulus fibers. The structure of the frame is certainly refined and advanced, intended to provide a low overall weight, high rigidity, but with a better absorption to vibration. The 888 Superking series have been characterized by this component of vibration damping, unique and harmonious distributed uniformly on the structure of the rear seat tube and fork. Proposal with regular geometry, and in 8 sizes.

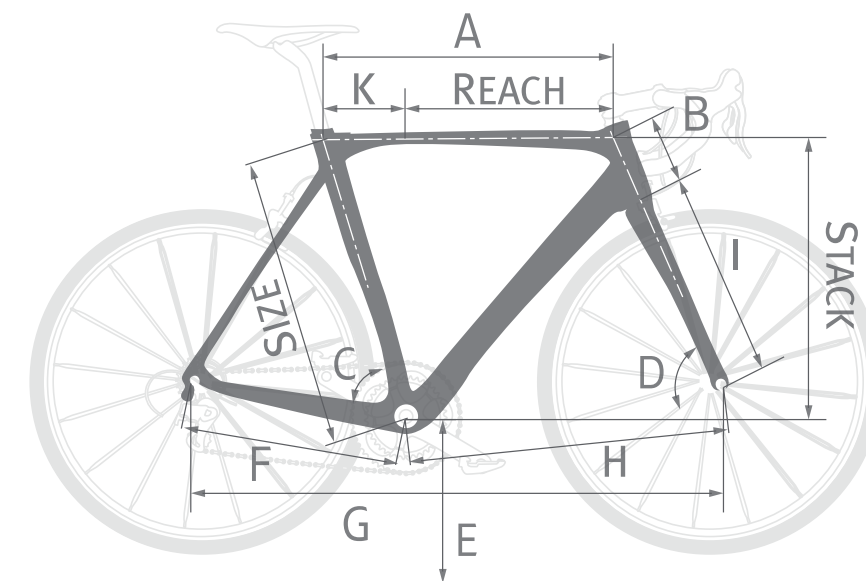

SIZE	Acm	Bcm	C°	D°	Ecm	Fcm	Gcm	Hcm	Icm	Kcm	REACH	STACK
46	50,3	8,2	74°60'	70°70'	7	39,6	95,5	56,9	36,8	12,2	36,9	47,8
48	51,6	10	74°30'	70°90'	7	39,6	96,4	57,9	36,8	13	37,4	49,6
50	52,8	11,8	74°	71°20'	7	39,8	97,5	58,7	36,8	13,8	37,9	51,4
52	54,1	13,6	73°70'	71°40'	7	39,8	97,8	58,8	36,8	14,6	38,4	53,2
54	55,3	14,8	73°40'	72°70'	7	40	98,4	59,6	36,8	15,4	38,9	55
56	56,7	16,6	73°10'	72°90'	7	40	98,6	59,6	36,8	16,3	39,4	56,8
58	58	18,4	72°80'	73°20'	7	40,2	99,6	60,4	36,8	17,2	39,9	58,6
60	59,4	20,2	72°50'	73°40'	7	40,2	100,4	61,2	36,8	18	40,4	60,4



# 888 Superking E



telaio/frame: **888 SUPERKING E**  
gruppo/group: **CAMPAGNOLO SUPER RECORD EPS**  
reggisella/seatpost: **DE ROSA**  
pedali/pedals: **LOOK BLADE**  
curva/handlebar: **FSA K-FORCE CT**  
attacco/stem: **FSA OS99**  
ruote/wheels: **CAMPAGNOLO BORA**  
gomme/tires: **VITTORIA OPEN CX**  
portaborraccia/bottlecage: **CARBON DE ROSA**  
sella/saddle: **SELLE ITALIA SLR**  
colore/color: **NERO GIALLO / BLACK NEON**







## 888 Superking R

Carbon

telaio/frame: 888 SUPERKING R  
 gruppo/group: SHIMANO ULTEGRA  
 reggisella/seatpost: DE ROSA  
 pedali/pedals: LOOK 2 MAX  
 curva/handlebar: FSA ENERGY CT  
 attacco/stem: FSA SL-K  
 ruote/wheels: FULCRUM R3  
 gomme/tires: VITTORIA RUBINO PRO  
 portaborraccia/bottlecage: CARBON DE ROSA  
 sella/saddle: SELLE ITALIA SL  
 colore/color: BIANCO / WHITE



## 888 Superking SR

Carbon

telaio/frame: 888 SUPERKING SR  
 gruppo/group: CAMPAGNOLO ATHENA  
 reggisella/seatpost: DE ROSA  
 pedali/pedals: LOOK 2 MAX  
 curva/handlebar: FSA ENERGY CT  
 attacco/stem: FSA SL-K  
 ruote/wheels: CAMPAGNOLO SCIROCCO 35  
 gomme/tires: VITTORIA RUBINO PRO  
 portaborraccia/bottlecage: CARBON DE ROSA  
 sella/saddle: SELLE ITALIA SL  
 colore/color: NERO GIALLO BLU / BLACK



# Idol



IDOL, un must della produzione De Rosa, un modello che racchiude l'esperienza De Rosa e risponde alle nuove tendenze del ciclismo su strada. IDOL è una bici concepita pensando all'impiego dei freni a disco. Le prerogative strutturali della Nuova IDOL sono legate ad un arricchimento della struttura portante dove la presenza del freno a disco e la frenata stessa lo richieda. Il suo design, le geometrie e i materiali utilizzati sono ottimizzati per l'utilizzo dei freni a disco, ma naturalmente IDOL accetta i classici freni tradizionali per chi voglia mantenere le soluzioni tradizionali senza rinunciare ad un telaio di ultima generazione e dal design futuristico. Il telaio della IDOL è realizzato in fibra SUPER HI-MODUL con un blend di T1000 (70%) e T800 (30%) garantendo così una rigidità strutturale ed un'ottima capacità di assorbimento. IDOL è proposta in 6 taglie.

IDOL, a must in the De Rosa production, a model that encompasses the De Rosa experience and give and answer to the new road cycling trends. IDOL is a bike conceived and designed for the utilization of disc brakes. The structural specifications of the new IDOL are connected to the improvement of the load-bearing structure where the presence of a disc brake and the consequent braking power requires it. Its design, geometries and materials utilized are optimized for utilization with a disc brake, but obviously IDOL also accepts the classical traditional brakes for those who follow traditional solutions without renouncing the latest generation and futuristic design frames. The IDOL frame is made from SUPER HI-MODUL fibre with a blend of T1000 (70%) and T800 (30%), thereby guaranteeing structural rigidity and an absorption capacity at maximum levels. IDOL is offered in 6 frame sizes.

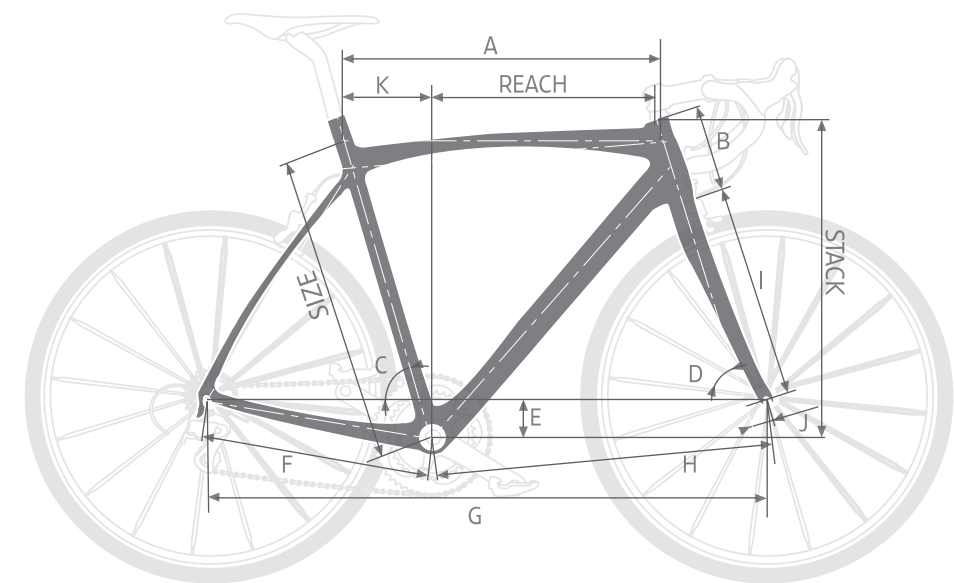

SIZE	Acm	Bcm	C°	D°	Ecm	Fcm	Gcm	Hcm	Icm	Kcm	REACH	STACK
47	51,7	11,1	74°20'	71°	7	40,6	97,3	57,8	36,8	12,8	37,0	50,7
49,5	52,9	11,8	73°90'	72°	7	40,8	97,8	58	36,8	13,7	37,8	51,7
52	54,3	13,5	73°60'	72°60'	7	40,8	97,7	58	36,8	14,5	38,4	53,7
54,5	56	15,4	73°	73°	7	41	98,8	58,8	36,8	15,9	39	55,7
57	57,2	17,5	73°	73°10'	7	41	99,9	59,9	36,8	16,5	39,6	57,7
59,5	58,8	19,5	72°70'	73°30'	7	41,2	101,1	60,9	36,8	17,5	40,2	59,7

# Idol Disk



telaio/frame: **IDOL DISK**  
gruppo/group: **SHIMANO DURA-ACE**  
reggisella/seatpost: **FSA K-FORCE**  
pedali/pedals: **LOOK BLADE**  
curva/handlebar: **FSA K-FORCE CT**  
attacco/stem: **FSA OS99**  
ruote/wheels: **SHIMANO**  
gomme/tires: **VITTORIA OPEN CX**  
portaborraccia/bottlecage: **CARBON DE ROSA**  
sella/saddle: **SELLE ITALIA SLR**  
colore/color: **GRIGIO / GREY**







**Idol**  
Carbon

telaio/frame: IDOL  
 gruppo/group: SHIMANO ULTEGRA  
 reggisella/seatpost: FSA SL-K  
 pedali/pedals: LOOK 2 MAX  
 curva/handlebar: FSA ENERGY CT  
 attacco/stem: FSA SL-K  
 ruote/wheels: FSA VISION DE ROSA  
 gomme/tires: VITTORIA RUBINO PRO  
 portaborraccia/bottlecage: CARBON DE ROSA  
 sella/saddle: SELLE ITALIA SL  
 colore/color: BIANCO AZZURRO / WHITE BLUE SKY



**Idol**  
Carbon

telaio/frame: IDOL  
 gruppo/group: CAMPAGNOLO CHORUS EPS  
 reggisella/seatpost: FSA SL-K  
 pedali/pedals: LOOK 2 MAX  
 curva/handlebar: FSA ENERGY CT  
 attacco/stem: FSA SL-K  
 ruote/wheels: CAMPAGNOLO EURUS  
 gomme/tires: VITTORIA OPEN CX  
 portaborraccia/bottlecage: CARBON DE ROSA  
 sella/saddle: SELLE ITALIA FLITE  
 colore/color: NERO ROSSO / RED DEVIL

# Planet



Una novità importante nella gamma De Rosa è il ritorno di "Planet".  
 Un telaio che in passato ebbe un grande successo. Oggi Planet viene riproposto in fibra di carbonio, posizionandolo nella gamma media, in modo da poter offrire un invidiabile rapporto qualità/prezzo, nonostante il telaio abbia tutte le caratteristiche di un telaio di alta gamma. Infatti Planet è proposto e prodotto in tessuto unidirezionale di super alto modulo, movimento centrale da 46 mm e diametro di 68 mm, sterzo differenziato, 1,1/8" nella parte superiore, 1, 1/2" in quella inferiore. Predisposto per il montaggio di gruppi elettronici e con cablaggi totalmente interni, Planet è proposto con geometria "light sloope" in 5 taglie.

An important innovation between De Rosa new range is the return of "Planet".  
 In the past this frame had lot of success. Nowadays Planet is proposed again in carbon fibre, placed in the medium range, in order to offer an enviable price/quality ratio, although the frame has all the characteristics of a high level frame. In fact, Planet is proposed and produced in uni-directional super high-modul carbonium, bottom bracket of 46mm and diameter 68mm, differentiated headset diameter, 1/1,8" in the upper part , 1,1/2" in the lower part. Developed to be assembled with electrical groups and inner wiring, Planet is suggested with "light sloope" geometry in 5 sizes.

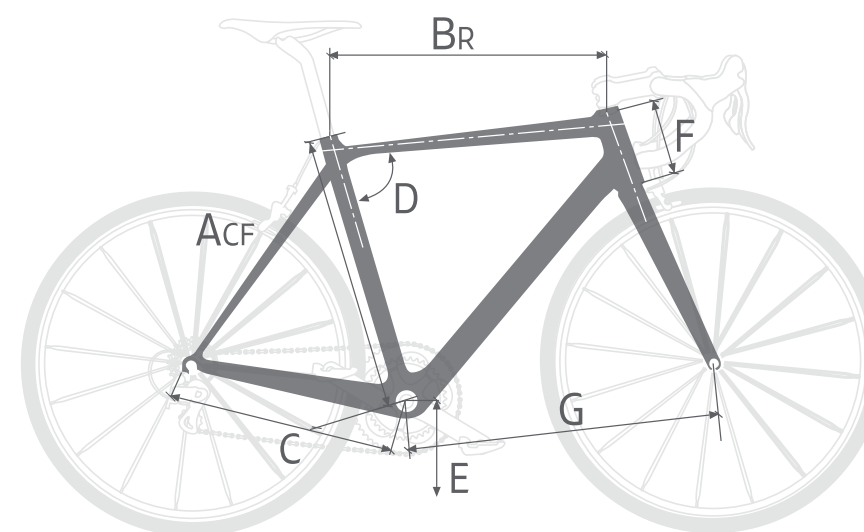

ACF	BR	C	D°	E	F	G
47	51,4	40,6	74°50'	26,8	11	57,4
50	52,5	40,6	74°50'	26,8	12,2	57,7
53	53,8	40,6	74°50'	26,5	14,5	58,3
55	55,5	40,6	73°50'	26,5	16	58,9
58	57	40,9	73°	26,5	19,5	59,9



# Planet



telaio/frame: **PLANET**  
gruppo/group: **SHIMANO 105 11S**  
reggisella/seatpost: **FSA GOSSAMER**  
pedali/pedals: **LOOK EASY**  
curva/handlebar: **FSA VERO CT**  
attacco/stem: **FSA OS168**  
ruote/wheels: **FULCRUM R7**  
gomme/tires: **VITTORIA RUBINO PRO**  
portaborraccia/bottlecage: **CUSTOM RACE DE ROSA**  
sella/saddle: **SELLE ITALIA SL**  
colore/color: **BIANCO NERO ROSSO / BLACK CLASSIC**





# Planet

Carbon

telaio/frame: PLANET  
 gruppo/group: SHIMANO 105 11S  
 reggisella/seatpost: FSA GOSSAMER  
 pedali/pedals: LOOK EASY  
 curva/handlebar: FSA VERO CT  
 attacco/stem: FSA OS168  
 ruote/wheels: FULCRUM R7  
 gomme/tires: VITTORIA RUBINO PRO  
 portaborraccia/bottlecage: CUSTOM RACE DE ROSA  
 sella/saddle: SELLE ITALIA SL  
 colore/color: GRIGIO ROSSO / DARK GREY



# Planet

Carbon

telaio/frame: PLANET  
 gruppo/group: CAMPAGNOLO VELOCE  
 reggisella/seatpost: FSA GOSSAMER  
 pedali/pedals: LOOK EASY  
 curva/handlebar: FSA VERO CT  
 attacco/stem: FSA OS168  
 ruote/wheels: CAMPAGNOLO KHAMSIN  
 gomme/tires: VITTORIA RUBINO PRO  
 portaborraccia/bottlecage: CUSTOM RACE DE ROSA  
 sella/saddle: SELLE ITALIA SL  
 colore/color: NERO BLU / NEON BLUE



# R838



Proposta di grande spessore per il nostro telaio "entry level", di grande bellezza, con contenuti tecnici degni di un telaio di segmento superiore. Caratteristiche salienti sono il telaio in Monoscocca di carbonio/K3, la serie sterzo 1,1/8" nel top e 1,1/4" bottom, la predisposizione per movimento centrale BB30 ed il cablaggio interno dei cavi. Cinque le taglie proposte, nelle prime due taglie il rake delle forcelle è di 50 mm, per ottimizzare la stabilità. Oltre ai notevoli contenuti tecnici R838 si avvale di una grafica curata ed attraente. La ricercata cura dei dettagli anche in questo prodotto non pregiudica un rapporto qualità/prezzo invidiabile.

A proposal of great depth for our "entry level" frame of great beauty, with the technical contents worthy of a high-end segment frame. Main features are the frame made as carbon/K3 Monocoque, series head tube 1,1/8" at the top and 1,1/4" bottom, set up for bottom bracket BB30 and internal cabling. Five sizes proposed, in the first two sizes the rake of the forks is 50 mm, to maximize stability. In addition to the outstanding technical contents R838 benefits from impeccable and new attractive graphics. The exquisite attention to details also in this product does not affect an enviable price/quality ratio.

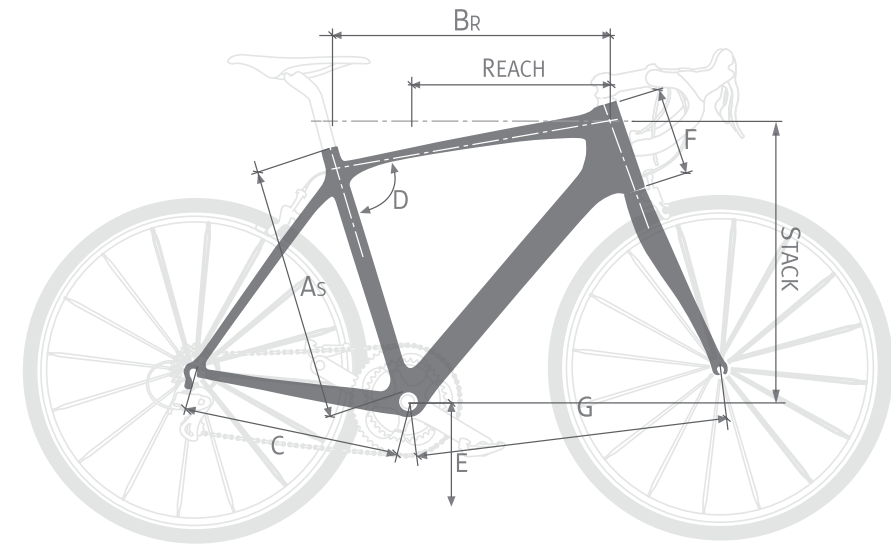

SLOPE								
AScm	BRcm	Ccm	D°	Ecm	Fcm	Gcm	REACH	STACK
43	51,5	40,6	74°5'	26,8	10,23	56,66	37,5	50,5
45	53,16	40,6	74°1'	26,8	12,56	57,7	38,2	52,5
48	54,84	40,6	73°7'	26,8	14,5	58,9	38,9	54,5
50	56,55	40,6	73°3'	26,8	16,53	60	39,6	56,5
53	58,3	40,6	72°9'	26,8	18,27	60,4	40,3	58,5



# R838



telaio/frame: R838  
gruppo/group: CAMPAGNOLO VELOCE BASE  
reggisella/seatpost: FSA GOSSAMER  
pedali/pedals: LOOK EASY  
curva/handlebar: FSA VERO CT  
attacco/stem: FSA OS168  
ruote/wheels: CAMPAGNOLO KHAMSIN  
gomme/tires: VITTORIA RUBINO PRO  
portaborraccia/bottlecage: CUSTOM RACE DE ROSA  
sella/saddle: SELLE ITALIA SL  
colore/color: BIANCO ROSSO BLU / WHITE RED

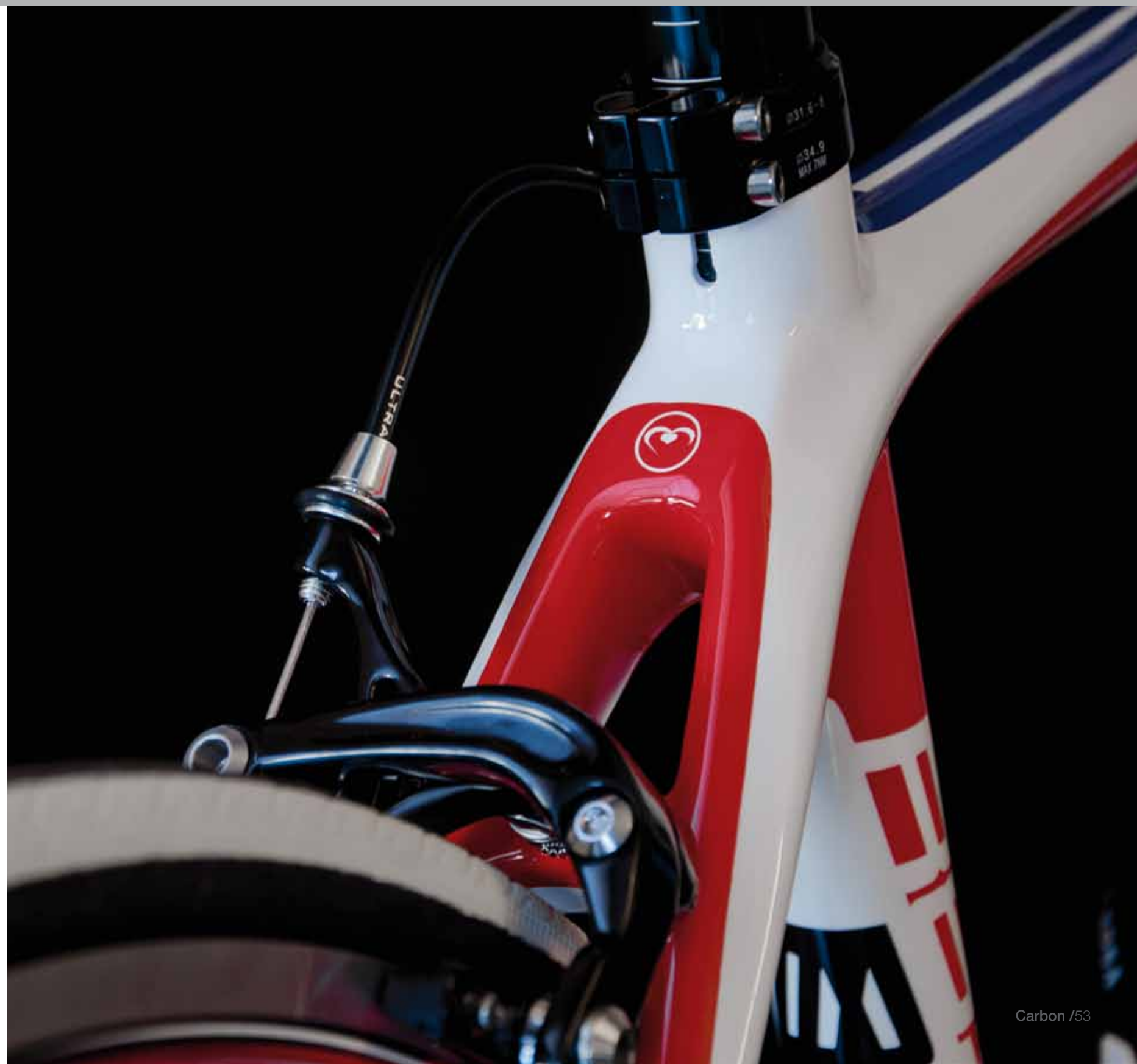





**R838**  
Carbon

telaio/frame: R838  
 gruppo/group: SHIMANO 105 11S  
 reggisella/seatpost: FSA GOSSAMER  
 pedali/pedals: LOOK EASY  
 curva/handlebar: FSA VERO CT  
 attacco/stem: FSA OS168  
 ruote/wheels: FULCRUM R7  
 gomme/tires: VITTORIA RUBINO PRO  
 portaborraccia/bottlecage: CUSTOM RACE DE ROSA  
 sella/saddle: SELLE ITALIA SL  
 colore/color: BLACK W / BLACK W



**R838**  
Carbon

telaio/frame: R838  
 gruppo/group: CAMPAGNOLO VELOCE  
 reggisella/seatpost: FSA GOSSAMER  
 pedali/pedals: LOOK EASY  
 curva/handlebar: FSA VERO CT  
 attacco/stem: FSA OS168  
 ruote/wheels: CAMPAGNOLO KHAMSIN  
 gomme/tires: VITTORIA RUBINO PRO  
 portaborraccia/bottlecage: CUSTOM RACE DE ROSA  
 sella/saddle: SELLE ITALIA SL  
 colore/color: FRAGOLA / CORAL



# Formula King



Il progetto "FORMULA KING" è il frutto di una sinergia nata tra la nostra esperienza nel mondo delle corse, uno studio ingegneristico e le richieste dei corridori professionisti. FORMULA KING è un prodotto ricco di grandi contenuti tecnici e come tale è destinato alle corse contro il tempo, disciplina dove l'aerodinamica e la biomeccanica sono fondamentali per ottenere un telaio che consenta prestazioni sempre più performanti. Il progetto "FORMULA KING" ha il telaio realizzato con una struttura monoscocca dove l'utilizzo della fibra di carbonio unidirezionale conferisce rigidità e leggerezza, qualità fondamentali per ottenere risultati elevati. Ha l'attacco manubrio "integrato", di fatto un'appendice ed una continuazione del telaio stesso. Un'ulteriore scelta tecnica è la posizione del freno posteriore, che scompare tra le linee tese e muscolose della scatola movimento, non compromettendone l'aerodinamica e la frenata. Inoltre per soddisfare maggiormente le esigenze degli atleti, si è voluto aggiungere una taglia in più rispetto alla generale tendenza di limitare a 3 tale scelta.

"FORMULA KING" is the result of a synergy born between our experience in the racing world, the engineering study and requests of our professional riders. FORMULA KING is a product full of great technical contents and as such is for time trial, which requires aerodynamic and biomechanic qualities to have a frame with higher level performances. "FORMULA KING" project has the frame made as a monocoque structure that uses an unidirectional fiber that gives stiffness and lightness, important to have a very high results. Design features an integrated stem which is in fact the continuation of the frame itself. A further integration is the rear brake; it disappears into the bottom bracket design. So to meet the professional riders requests we have added a size more respect the general trend limited at 3 sizes.

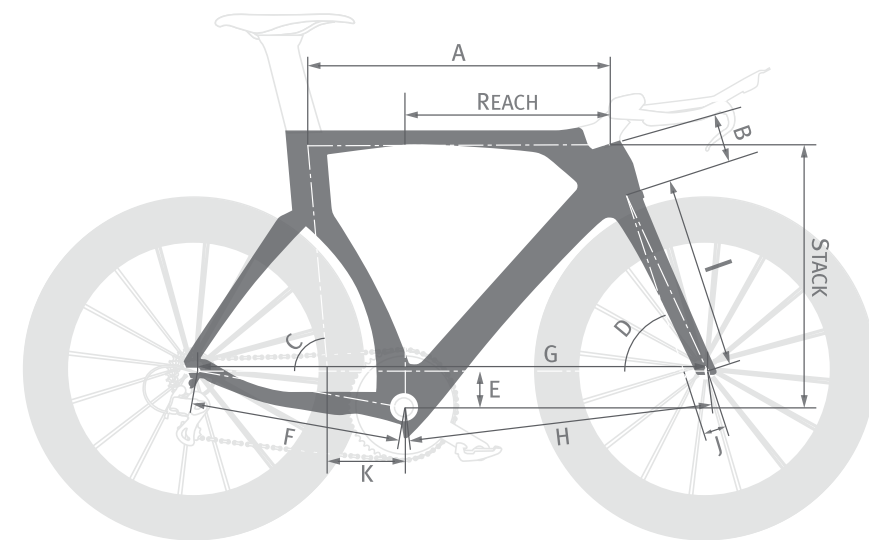

REGULAR													
SIZE	Acm	Bcm	C°	D°	Ecm	Fcm	Gcm	Hcm	Icm	Jcm	Kcm	REACH	STACK
55,9	55,9	9,1	85°	71°50'	7	40	95,5	56,5	36,6	43	14,7	37,5	49
57,5	57,5	10	85°	72°	7	40	96,9	57,9	36,6	43	14,7	39	50
59	58	10,9	75°	72°50'	7	40	98	59,3	36,6	43	14,7	40,5	510
60,6	60,6	11,8	85°	73°	7	40	99,6	60,6	36,6	43	14,7	42	520



# Formula King



telaio/frame: **FORMULA KING**  
gruppo/group: **CAMPAGNOLO SUPER RECORD BORA**  
reggisella/seatpost: **DE ROSA**  
pedali/pedals: **LOOK BLADE**  
curva/handlebar: **FSA TRIMAX**  
attacco/stem: **DE ROSA**  
ruote/wheels: **BORA80+ BORA TTCAMPAGNOLO**  
gomme/tires: **VITTORIA OPEN CX**  
sella/saddle: **SELLE ITALIA SLR**  
colore/color: **BLACK RED**





Nato unico e su misura, per questo è "Solo"...

Born unique and on measure, for this reason it's "Solo"...

# Titanio Solo

## Custom Size

L'evoluzione della specie nel Titanio si chiama SOLO....  
Un telaio esclusivo, SOLO per pochi eletti, SOLO per chi è oltre alle mode, SOLO per chi ama i metalli ed il titanio nella sua forma più pura, SOLO in Titanio grado 9!  
Le tubazioni (a triplo spessore) utilizzate sono aumentate di diametro senza penalizzare in modo significativo il peso.  
Diametro da 42 mm per il tubo obliquo, dove alle estremità sono previste delle sezioni semi ellittiche, volte ad ottimizzare le sollecitazioni alla torsione ed al contempo sovraperformare la rigidità alla scatola del movimento centrale.  
Diametro da 35 mm per il tubo orizzontale e per il tubo sella.  
Tubo sella dove potrà alloggiare comodamente la batteria dedicata ai gruppi elettronici. Tubazioni, forcellini, tubo sterzo estratto in CNC, minuteria SOLO in Titanio di grado 9!  
SOLO per chi ama la vera eccellenza italiana.  
Telaio costruito SOLO su misura! Come sempre, da sempre....

The evolution made of Titanium is called SOLO...  
An exclusive frame , only for a few chosen people, only for those who are fashionable, only for those who love metals and pure titanium, frame only made of titanium degree 9.  
The used pipes characterized by a triple thickness have a bigger diameter without penalizing the weight.  
The oblique tube has a diameter of 42mm , at the end of which there are semi elliptical sections, in order to optimize the torsion solicitations and to performance in a better way the rigidity of the box at the central movement. The horizontal tube and the saddle tube have a diameter of 35mm. The battery of electrical groups can stay on the tube saddle without any problem.  
Tubes, forks, head tube extracted in CNC, objects only made of Titanium degree 9. Only for those who love the italian excellence/ high level. Frame (manufactured) only Made to Measure, as always, since the beginning...







# Titanio Solo Titanium

telaio/frame: TITANIO SOLO  
 gruppo/group: CAMPAGNOLO SUPER RECORD EPS  
 reggisella/seatpost: DE ROSA CARBON  
 pedali/pedals: LOOK BLADE  
 curva/handlebar: FSA K-FORCE  
 attacco/stem: FSA K-FORCE  
 ruote/wheels: FSA METRON DE ROSA  
 gomme/tires: VITTORA OPEN CX  
 portaborraccia/bottlecage: CARBON DE ROSA  
 sella/saddle: SELLE ITALIA SLR  
 colore/color: TITANIO / TITANIUM





# Titanio 3/2.5

## Custom Size

Il titanio è un metallo conosciuto per il suo alto rapporto resistenza/peso, per la leggerezza e la durezza. TITANIO 3/2.5 è un telaio che va oltre le mode, pensato e prodotto per gli amanti di oggetti unici. Intramontabile per classe e stile, è dotato di grandi valenze tecnologiche. Il telaio TITANIO 3/2.5 viene prodotto con tubazioni speciali in lega di Titanio: TI3AL-2,5V a doppio spessore. Il tubo sterzo è ricavato dal pieno a CNC, come anche i forcellini. A differenza di tanti altri produttori, De Rosa produce questo telaio interamente in grado 9, carro posteriore e minuteria compresi. Un capolavoro firmato De Rosa, dove il vero Titanio esalta le sue doti di leggerezza e resistenza meccanica. Rigorosamente e solo su misura.

Titanium is a metal renowned for its strength-to-weight ratio, lightness and hardwearing qualities. TITANIO 3/2.5 is a frame that goes beyond fashion, designed and produced for those who love unique objects. Timeless in terms of its class and style, it adopts technology at the cutting edge. The TITANIO 3/2.5 frame is produced with special tubes in titanium alloy: double-thickness TI3AL-2,5V. The steering tube is CNC machined, as are the fork ends. Unlike other frame makers, De Rosa produces this frame with material in degree 9, included rear seat, chain stays and minuteria. A masterpiece with the De Rosa trademark, in which genuine titanium enhances its qualities of lightness and mechanical resistance. Strictly and only made to measure.







# Titanio 3/2.5



telaio/frame: TITANIO 3/2.5  
gruppo/group: CAMPAGNOLO SUPER RECORD EPS  
reggisella/seatpost: TITANIO  
pedali/pedals: LOOK BLADE  
curva/handlebar: FSA K-FORCE CT  
attacco/stem: FSA OS99  
ruote/wheels: CAMPAGNOLO BORA 50  
gomme/tires: VITTORIA OPEN CX  
portaborraccia/bottlecage: CARBON DE ROSA  
sella/saddle: SELLE ITALIA SLR  
colore/color: NERO / TITAN GREY

Colori personalizzabili / Custom colors available



# Scattofisso 737

## Custom Size



telaio/frame: SCATTOFISSO 737  
gruppo/group: MICHE  
ruote/wheels: MICHE  
colore/color: SILVER NEON

SCATTOFISSO 737 per gli amanti delle "fixed".  
De Rosa interpreta a suo modo questo tipo di  
bicicletta, con una soluzione tanto coraggiosa  
quanto attraente. Telaio in Lega di Alluminio  
7000, geometria Slope Reverse per aggredire  
la strada, tubo sella sagomato per una migliore  
maneggevolezza e guidabilità posteriore.  
3 Misure disponibili.  
Una bici per il divertimento e la velocità pura.  
SCATTOFISSO 737, un sogno possibile.

SCATTOFISSO 737 For lovers of "fixed bikes".  
De Rosa gives a new interpretation at this kind of  
bike, with a solution as much valiant as seductive  
Frame in 7000 aluminium alloy, Slope Reverse  
geometry to attack the road, saddle tube profiled  
for a greater manageability and rear easy driving.  
Three sizes are available.  
A bike that goes against the trend.  
A bike for enjoyment and pure speed.  
SCATTOFISSO 737, a possible dream.







# Corum

## Custom Size



telaio/frame: CORUM  
gruppo/group: CAMPAGNOLO CHORUS  
reggisella/seatpost: TITANIO  
pedali/pedals: LOOK 2 MAX  
curva/handlebar: FSA ENERGY CT  
attacco/stem: FSA SLK  
ruote/wheels: CAMPAGNOLO SHAMAL MILLE  
gomme/tires: VITTORIA OPEN CX  
portaborraccia/bottlecage: CARBON DE ROSA  
sella/saddle: SELLE ITALIA FLITE  
colore/color: ROSSO / RED DEVIL

CORUM... Acciaio e Passione!

Interpretazione moderna dell'acciaio, per la sua tecnica di costruzione artigianale con saldature TIG e l'utilizzo di acciaio legato 18MCDV6.

Il telaio CORUM viene costruito solo su misura, ed è disponibile sia con geometria regolare che "slope". Lo sterzo è di tipo "integrato" e la forcella è in fibra di carbonio. Quest'anno viene introdotto il modello "Corum Disk", prodotto destinato agli amanti del freno a disco oleodinamico. Il telaio presenta tubazioni oversize, come anche il tubo sterzo, ed una scatola movimento da 86 mm.

CORUM... Steel and Passion!

A modern interpretation of steel, thanks to artisan construction techniques using TIG welding and the use of 18MCDV6 alloy steel. The CORUM frame is made to measure, customising both the regular geometry and the slope. Steering tube is an integrated type, while the fork is in carbon fibre.

This season has been introduced the new model "Corum Disk", product designed for the lovers of oil disk brake systems. The frame features oversize tubes, as the steering tube, and an oversize 86 mm bottom bracket.







## Corum Acciaio

telaio/frame: CORUM  
gruppo/group: CAMPAGNOLO ATHENA  
reggisella/seatpost: TITANIO  
pedali/pedals: LOOK 2 MAX  
curva/handlebar: FSA ENERGY CT  
attacco/stem: FSA SLK  
ruote/wheels: CAMPAGNOLO ZONDA  
gomme/tires: VITTORIA RUBINO PRO  
portaborraccia/bottlecage: CARBON DE ROSA  
sella/saddle: SELLE ITALIA SL  
colore/color: BIANCO / WHITE



## Corum disk Acciaio

telaio/frame: CORUM  
gruppo/group: SHIMANO ULTEGRA D12  
reggisella/seatpost: FSA SL-K  
pedali/pedals: LOOK 2 MAX  
curva/handlebar: FSA ENERGY CT  
attacco/stem: FSA SLK  
ruote/wheels: FSA VISION T30  
gomme/tires: VITTORIA OPEN CX  
portaborraccia/bottlecage: CARBON DE ROSA  
sella/saddle: SELLE ITALIA SL  
colore/color: NERO / NERO BLUETTE





# Nuovo classico



**NUOVO CLASSICO...indimenticabile!**  
 Il fascino dell'acciaio è rimasto inalterato nel tempo. Gli amanti di questo materiale sono molti ed i telai NUOVO CLASSICO vengono prodotti ancora artigianalmente: realizzati da tanti anni con la stessa sapiente tecnica, saldobrasandone le congiunzioni in micro fusione, rifinendo poi a mano tutti gli elementi, con maniacale attenzione ai dettagli. Questo telaio è la sintesi della più antica tradizione telaistica Italiana e De Rosa ne è il portabandiera. Forcella in acciaio e costruzione telaio su misura.

**NUOVO CLASSICO... unforgettable!**  
 The fascination of steel has remained unchanged over time. There are still many who value this material and the NUOVO CLASSICO frames are produced for them with the same artisan knowledge: since many years the frames have been made with the same technical expertise, with micro-fusion welding of joints, followed by finishing of all the elements by hand with obsessive attention for every detail. This frame sums up the most long-standing Italian frame-building tradition and De Rosa is the standard bearer. Steel fork and frame construction on measure.

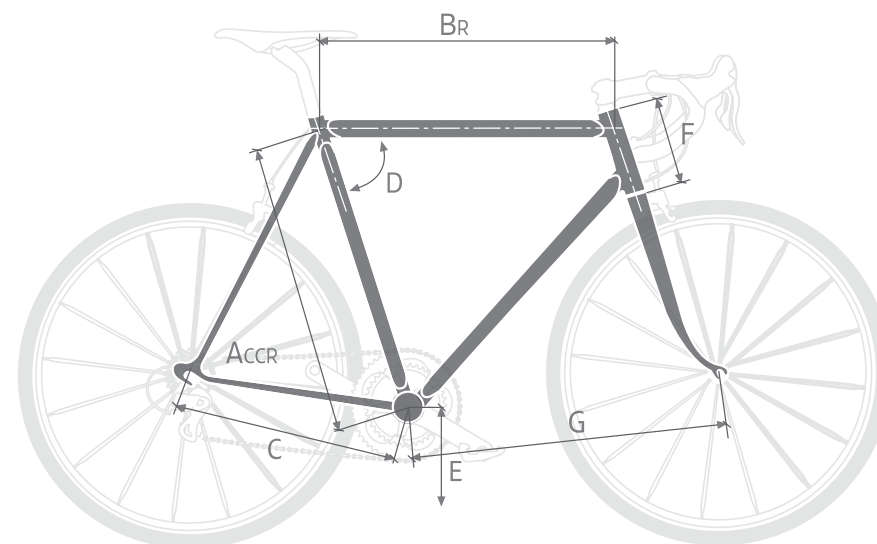

## REGULAR

ACCRcm*	BRcm	Ccm	D°	Ecm	Fcm	Gcm
48	52	40	75°30'	26,5	8,2	57,5
49	52	40	75°30'	26,5	9,2	57,5
50	52,5	40	75°15'	26,5	10,2	58
51	53	40	75°	26,5	10,9	58
52	53,5	40,3	74°30'	26,5	11,9	58
53	54	40,5	74°15'	26,5	12,6	58,2
54	54,5	40,7	74°	26,5	13,6	58,4
55	55	40,7	73°50'	26,5	14,4	58,6
56	56	40,8	73°10'	26,5	15,3	59
57	56,5	40,8	73°	26,5	16,3	59,4
58	57,5	40,8	73°	26,5	17,2	59,7
59	58	40,9	72°50'	26,5	18,2	60
60	58,5	41	72°45'	26,5	19,2	60,3
61	59	41,2	72°30'	26,5	20,2	60,8

\*Misura ACCR: centro/centro  
 \*Measurement ACCR: centre/centre  
 Misure indicative / Indicative sizes





# Nuovo classico

Acciaio

telaio/frame: NUOVO CLASSICO  
gruppo/group: CAMPAGNOLO RECORD  
reggisella/seatpost: DEDA  
pedali/pedals: LOOK 2 MAX  
curva/handlebar: DEDA  
attacco/stem: DEDA  
ruote/wheels: CAMPAGNOLO SHAMAL MILLE  
gomme/tires: VITTORIA OPEN CX  
portaborraccia/bottlecage: CARBON DE ROSA  
sella/saddle: SELLE ITALIA SLR  
colore/color: ROSSO CROMO / RED CHROME



# Nuovo classico

Acciaio

telaio/frame: NUOVO CLASSICO  
gruppo/group: CAMPAGNOLO CHORUS  
reggisella/seatpost: DEDA  
pedali/pedals: LOOK 2 MAX  
curva/handlebar: DEDA  
attacco/stem: DEDA  
ruote/wheels: CAMPAGNOLO ZONDA  
gomme/tires: VITTORIA OPEN CX  
portaborraccia/bottlecage: CARBON DE ROSA  
sella/saddle: SELLE ITALIA FLITE  
colore/color: NERO OPACO / NERO OPACO



# Neo primato



Il fascino dell'acciaio è rimasto inalterato nel tempo nonostante l'avvento di materiali più leggeri. Gli estimatori di questo materiale sono molti ed i telai NEO PRIMATO vengono a loro dedicati e prodotti ancora artigianalmente come 50 anni fa. I telai sono realizzati da sempre con la stessa sapiente tecnica, saldobrasandone le congiunzioni in microfusione, rifinando poi a mano tutti gli elementi con cura nei dettagli. Forcella in acciaio e disponibilità in 14 taglie.

The fascination of steel has remained unchanged over time, despite the arrival of lighter materials. There are still many who value this material and the NEO PRIMATO frames are dedicated and produced for them with the same artisan care adopted 50 years ago. From the very beginning the frames have been made with the same technical expertise, with micro-fusion welding of joints, followed by finishing of all the elements by hand with care for every detail. This frame sums up the most long-standing Italian frame-building tradition and De Rosa is the standard bearer. Steel fork and availability in 14 sizes.

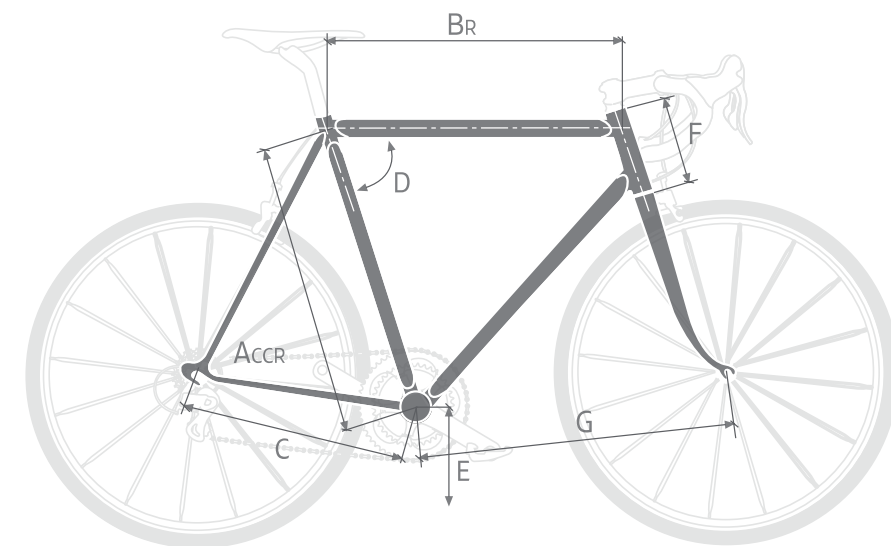

## REGULAR

ACCRcm*	BRcm	Ccm	D°	Ecm	Fcm	Gcm
48	52	40	75°30'	26,5	8,2	57,5
49	52	40	75°30'	26,5	9,2	57,5
50	52,5	40	75°15'	26,5	10,2	58
51	53	40	75°	26,5	10,9	58
52	53,5	40,3	74°30'	26,5	11,9	58
53	54	40,5	74°15'	26,5	12,6	58,2
54	54,5	40,7	74°	26,5	13,6	58,4
55	55	40,7	73°50'	26,5	14,4	58,6
56	56	40,8	73°10'	26,5	15,3	59
57	56,5	40,8	73°	26,5	16,3	59,4
58	57,5	40,8	73°	26,5	17,2	59,7
59	58	40,9	72°50'	26,5	18,2	60
60	58,5	41	72°45'	26,5	19,2	60,3
61	59	41,2	72°30'	26,5	20,2	60,8

\*Misura ACCR: centro/centro

\*Measurement ACCR: centre/centre





# Neoprimate

Acciaio

telaio/frame: **NEOPRIMATO**  
 gruppo/group: **CAMPAGNOLO ATHENA**  
 reggisella/seatpost: **FSA GOSSAMER**  
 pedali/pedals: **LOOK 2 MAX**  
 curva/handlebar: **FSA ENERGY CT**  
 attacco/stem: **FSA SL-K**  
 ruote/wheels: **CAMPAGNOLO ZONDA**  
 gomme/tires: **VITTORIA RUBINO PRO**  
 portaborraccia/bottlecage: **CARBON DE ROSA**  
 sella/saddle: **SELLE ITALIA SL**  
 colore/color: **VERDE / VERDE LONDON**



# Neoprimate

Acciaio

telaio/frame: **NEOPRIMATO**  
 gruppo/group: **CAMPAGNOLO ATHENA**  
 reggisella/seatpost: **FSA GOSSAMER**  
 pedali/pedals: **LOOK 2 MAX**  
 curva/handlebar: **FSA ENERGY CT**  
 attacco/stem: **FSA SL-K**  
 ruote/wheels: **CAMPAGNOLO ZONDA**  
 gomme/tires: **VITTORIA RUBINO PRO**  
 portaborraccia/bottlecage: **CARBON DE ROSA**  
 sella/saddle: **SELLE ITALIA SL**  
 colore/color: **BLU / GS BLUE**





# Scandium



Una novità rilevante nell'alto di gamma De Rosa è la nascita di "Scandium". Telaio che rientra nel progetto "Black Label" in quanto è un telaio che viene prodotto esclusivamente "Custom" nell'officina De Rosa. Le tubazioni impiegate sono in lega di alluminio ad altissima prestazione, lega arricchita di Scandio. Le elevate qualità meccaniche di questo materiale fanno sì che sia una valida alternativa alla fibra di carbonio. Il telaio risulta reattivo, leggero e rigido, adatto alle competizioni più impegnative ed agli amatori più agonisti. Realizzato "su misura", come nella filosofia che De Rosa ha sposato da sempre. Inoltre è possibile personalizzare anche la verniciatura.

The birth of "Scandium" is an important innovation of the high-range products that De Rosa can offer. Its frame belongs to the "Black label" project since it is exclusively "custom" produced in the De Rosa workshop. The used pipes are made of high-ranking aluminium alloy combined with Scandio. Thanks to the high mechanical qualities of this material, it can be a valid substitute for the carbon fibre. This frame is reactive, light and rigid, proper to the most competitive races and to the most agonistic amateurs. It is created with the philosophy belonging to De Rosa, the Made to Measure concept. In addition, it is possible to personalize the painting.

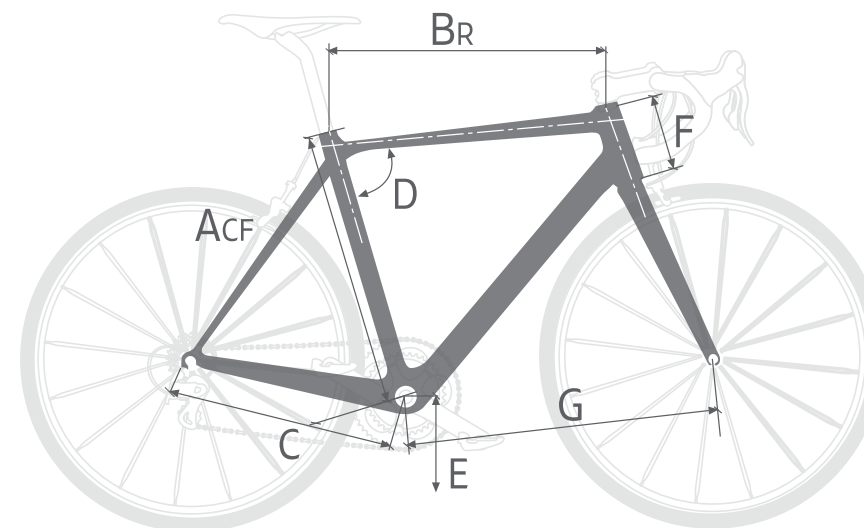

ACF	BR	C	D°	E	F	G
45 slope	52	40,5	75°	26,8	12,8	57,5
46,5 slope	53,5	40,5	74°50'	26,8	13,2	57,7
48 slope	54,5	40,7	74°30'	26,8	13,7	58,1
49 slope	55,5	40,7	74°	26,8	14,5	58,6
52 slope	56,5	41	73°	26,8	16,5	59
54 slope	57,5	41	73°	26,8	18,4	59,5
58 regolare	58,5	41,2	72°50'	26,8	18,4	60
60 regolare	60	41,2	72°50'	26,8	20,5	61



# Scandium



telaio/frame: **SCANDIUM**  
gruppo/group: **SHIMANO DURA-ACE**  
reggisella/seatpost: **FSA K-FORCE**  
pedali/pedals: **LOOK BLADE**  
curva/handlebar: **FSA K-FORCE CT**  
attacco/stem: **FSA OS99**  
ruote/wheels: **FSA VISION DE ROSA**  
gomme/tires: **VITTORIA OPEN CX**  
portaborracchia/bottlecage: **CARBON DE ROSA**  
sella/saddle: **SELLE ITALIA SLR**  
colore/color: **GRIGIO / SILVER GREY**





# Team



Team è un telaio di lega d'Alluminio e rappresenta la nostra proposta "Entry level". Prodotto in lega 7000, Team prevede l'utilizzo di un tubo sterzo over size a diametri differenziati, forcella dedicata in fibra di carbonio. Ottimo rapporto qualità/prezzo, reattività ed una notevole leggerezza, sono le peculiarità di Team. Saldature e finiture sempre di qualità elevata, anche se il telaio appartiene di fatto al segmento di "entrata", come del resto è da sempre nella filosofia De Rosa. Proposto in 4 taglie su geometria "Slope".

Team is a frame made of aluminium alloy and represents our proposal "Entry level". Team is made of alloy 7000 and it is characterized by the use of an over size steering tube with differentiated diameters and a fork made of carbon fibre. The features of Team is a great price/quality ratio, reactivity and remarkable lightness. Although the frame belongs to the "entry" segment, it is characterized by high-level weldings and finishings, following the De Rosa philosophy. Proposed in 4 sizes on "Slope" structure.

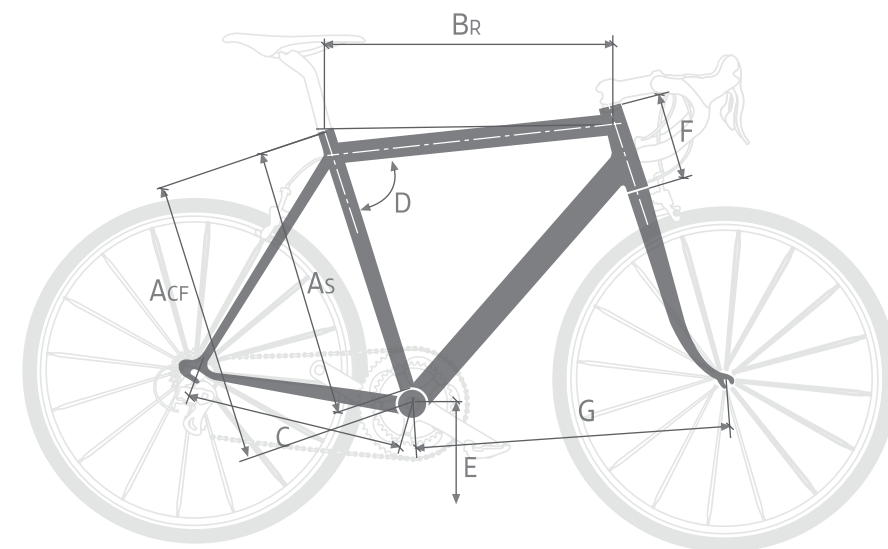

## SLOPE

A <sub>Scm</sub>	B <sub>Rcm</sub>	C <sub>cm</sub>	D°	F <sub>cm</sub>	G <sub>cm</sub>
45	52,5	40,1	75°	12,8	57,5
48	54	40,4	74°	13,7	58,1
52	56	40,6	73°	16,5	58,7
54	57,5	41,1	72°30'	18,4	59,5

# Team



telaio/frame: **TEAM**  
gruppo/group: **CAMPAGNOLO VELOCE**  
reggisella/seatpost: **FSA GOSSAMER**  
pedali/pedals: **LOOK EASY**  
curva/handlebar: **FSA VERO CT**  
attacco/stem: **FSA OS168**  
ruote/wheels: **CAMPAGNOLO KHAMSIN**  
gomme/tires: **VITTORIA RUBINO PRO**  
portaborraccia/bottlecage: **CUSTOM RACE DE ROSA**  
sella/saddle: **SELLE ITALIA SL**  
colore/color: **CLASSIC WHITE RED**









214  
Guanti Protos  
PROTOS gloves

204  
Maglia manica corta PROTOS verde  
Green PROTOS short sleeves jersey

200  
Maglia manica corta PROTOS rossa  
Red PROTOS short sleeves jersey

Collezione abbigliamento 2015  
Clothing collection 2015

# Spring Summer



203  
Pantaloncino PROTOS giallo  
Yellow PROTOS bib shorts

201  
Pantaloncino PROTOS rosso  
Red PROTOS bib shorts

205  
Pantaloncino PROTOS verde  
Green PROTOS bib shorts

202  
Maglia manica corta PROTOS gialla  
Yellow PROTOS short sleeves jersey



206  
Maglia manica corta ACTIVE bianca  
White ACTIVE short sleeves jersey



215  
Guanti neri  
Black gloves



208  
Maglia manica corta ACTIVE grigia  
Grey ACTIVE short sleeves jersey



209  
Pantaloncino ACTIVE grigio  
Grey ACTIVE bib shorts

207  
Pantaloncino ACTIVE bianco  
White ACTIVE bib shorts



258  
Cappellino bianco tricolore  
White cap with Italian flag

259  
Cappellino nero tricolore  
Black cap with Italian flag

212  
Maglia manica lunga LOGO  
LOGO long sleeves jersey

210  
Maglia manica corta LOGO  
LOGO short sleeves jersey

216  
Guanti bianchi  
White gloves

213  
Gilet bianco  
White gilet



211  
Pantaloncino LOGO  
LOGO bib shorts

220  
Calzini bianchi profilo nero rosso  
White socks with black red lines



237  
Maglia senza maniche grigio  
Grey sleeveless jersey



238  
Pantaloncino  
Shorts



# Women Spring Summer



236  
Maglia manica corta grigia  
Grey short sleeves jersey



234  
Maglia manica corta bianca  
White short sleeves jersey



235  
Maglia senza maniche bianco  
White sleeveless jersey

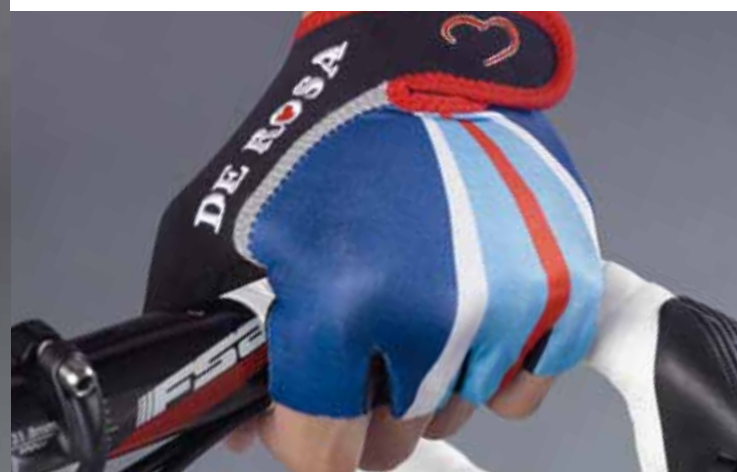

221  
Calzini bianchi profilo blu  
Blue line summer socks

219  
Calzini bianchi profilo argento  
Silver line summer socks

218  
Calzini bianchi  
White socks

217  
Guanti blu  
Blue gloves



# Fall Winter

226  
Maglia blu manica lunga  
Blue long sleeves jersey



232  
Guanti invernali  
Winter gloves

233  
Calzino invernale  
Winter sock

223 Copriscarpe medio bianco / 222 nero / Taglia unica  
223 White light shoe cover / 222 black / One size



229 Sottocasco nero - Black under helmet  
230 Sottocasco royal - Royal under helmet



224 Gambali  
Light leg warmers



264 Intimo manica lunga / taglia unica  
Long sleeves underwear / one size



227 Giubbino invernale  
Winter jacket



225 Manicotti  
Light arm warmers

231 Copriscarpe invernale  
Winter shoes cover



228 Calzamaglia  
Tights



248

T-shirt bianca con logo piccolo ricamato  
White T-shirt with small logo embroidered



249

T-shirt stampata I love DR nera / bianca / blu / gialla  
Printed t-shirt I love DR black / white / blue / yellow



Collezione abbigliamento 2015  
Clothing collection 2015

# Free time



263

Cappellino nero / rosso / crema  
Black / red / cream cap

251

T-shirt in jersey "Battito" bianca/blu/nera  
Jersey T-shirt "Battito" white/blue/black

262

Cappellino Drill nero  
Black Drill cap



254

Giubbino antivento / colore ghiaccio  
Windproof jacket / ice colour



247

T-shirt blu ricamata  
Blue embroidered T-shirt



245 T-shirt nera ricamata / Black embroidered T-shirt  
246 T-shirt bianca ricamata / White embroidered T-shirt



257

Felpa DR blu / grigia  
DR hoodie blue / grey



250

T-shirt stampata 1953 nera / gialla / bianca  
Printed t-shirt 1953 black / yellow / white

260

Cappellino estivo bianco  
White summer cap

261

Cappellino estivo blu  
Blue summer cap



243 Polo blu / Blue polo  
242 Polo bianca / White polo  
244 Polo nera / Black polo



252  
Giubbino navy  
Navy jacket



256  
Felpa JM nera / grigia / blu  
JM hoodie black / grey / blue



255  
Giacca melange profili neri  
Melange black lines jacket



239  
Pantaloncino sport bianco  
White sport shorts



240 Polo bianca con zip / White polo with zip  
241 Polo nera con zip / Black polo with zip



253  
Giubbino nero  
Black jacket



270 Grembiule / Work apron



273 Portaborraccia fiberglass  
Fiberglass bottlecage



272 Portaborraccia carbon  
Carbon bottlecage



266 Borsa porta ciclo  
Bike bag



269 Tappeto  
Carpet

267 Bandiera  
Flag



274 Sella SLR FLOW / SLR FLOW saddle  
275 Sella SLR / SLR saddle  
276 Sella SL / SL saddle



271 Portacamera  
Saddle bag



265 Nastro  
Handlebar tape









Via Bellini, 24 - 20095 Cusano Milanino - Milano - Italy - Tel. +39.02.61.95.171  
[derosa.it](http://derosa.it)